

DFM	2	GBPC12-35W	6
DFS	2	GBU	6
DO-201AD	2	GP20 / 1.5KE	6
DO-204AC (DO-15)	2	ITO-220AB	7
DO-204AH (GLASS DO-35)	2	ITO-220AC	7
DO-204AL (DO-41)	2	KBL	7
DO-204AL (GLASS DO-41)	2	KBPM / 2KBPM	8
DO-204AP	2	KBU	8
DO-213AA (GL34)	2	MELF (GLASS)	8
DO-213AB (GL41)	3	P600	8
DO-214AA (SMB)	3	SOD-80C (GLASS MINI MELF)	8
DO-214AB (SMC)	3	SOD-123	9
DO-214AC (SMA)	3	SOD-323	9
DO-214BA (GF1)	4	TO-220AB	9
DO-215AA (SMBG GULL WING)	4	TO-220AC	9
DO-215AB (SMCG GULL WING)	4	TO-226AA (TO-92)	10
DO-218	5	TO-236AB (SOT-23)	10
G3	5	TO-247AD (TO-3P)	10
G4	5	TO-263AB	11
GBL	5	TO-269AA / MBS	11
GBPC1/6	5	WG / 2WG	11
GBPC12-35	6		

All dimensions in inches and (millimeters)

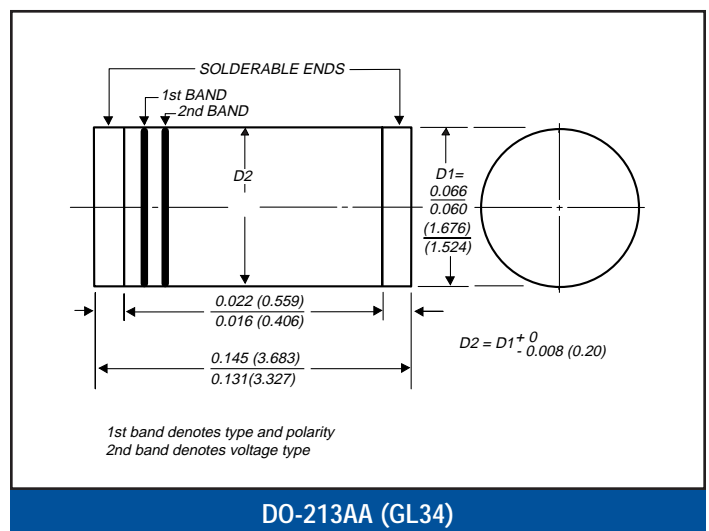

All dimensions in inches and (millimeters)

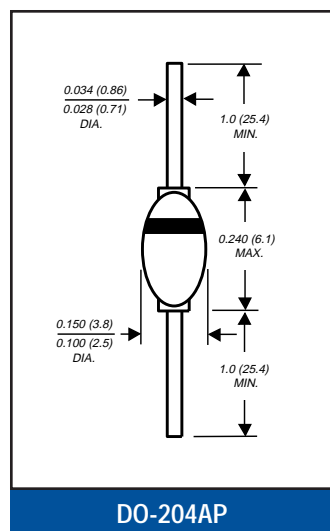
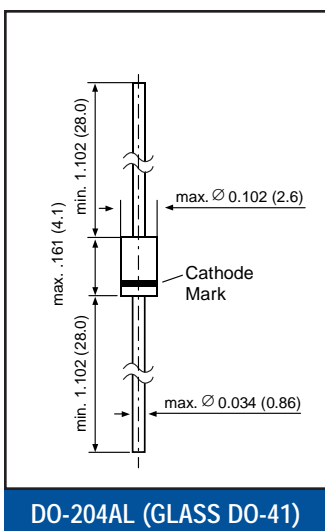
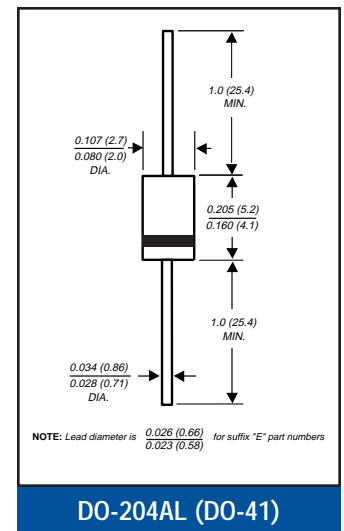
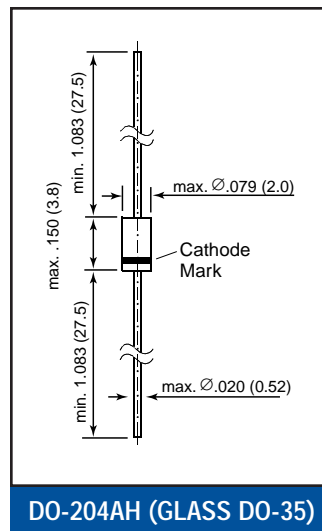
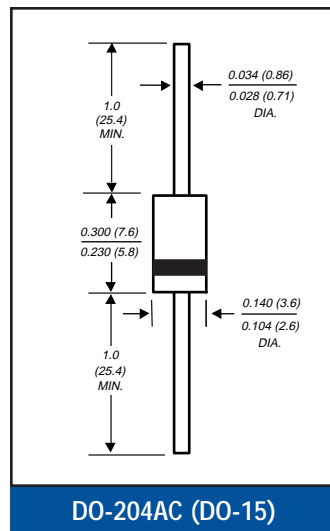
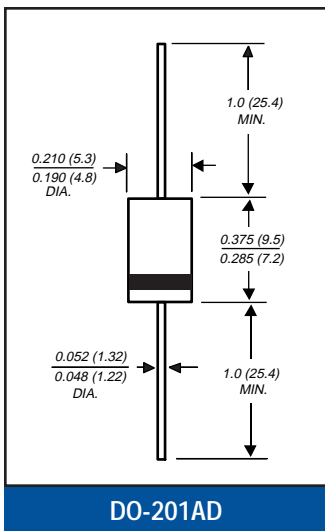
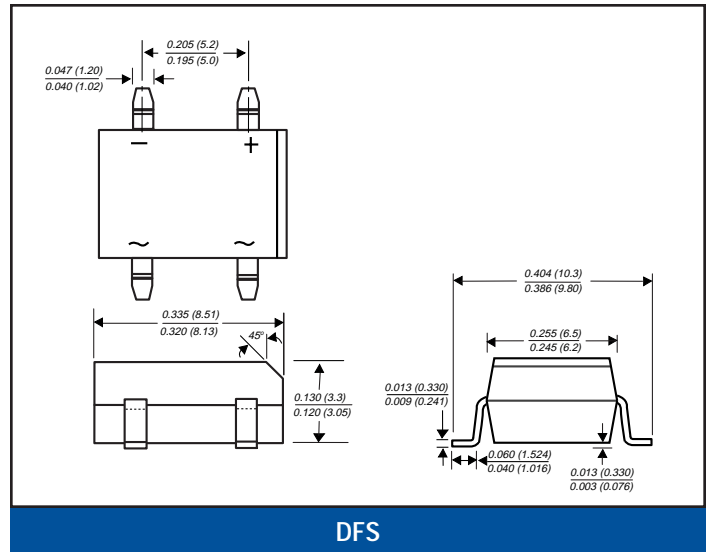
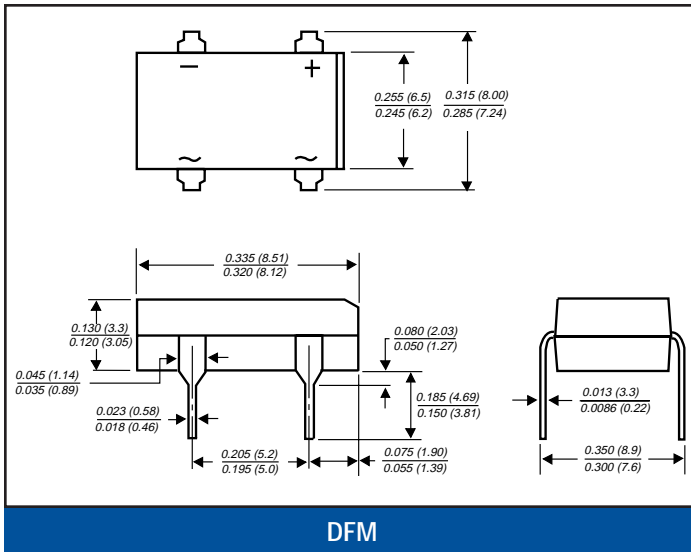
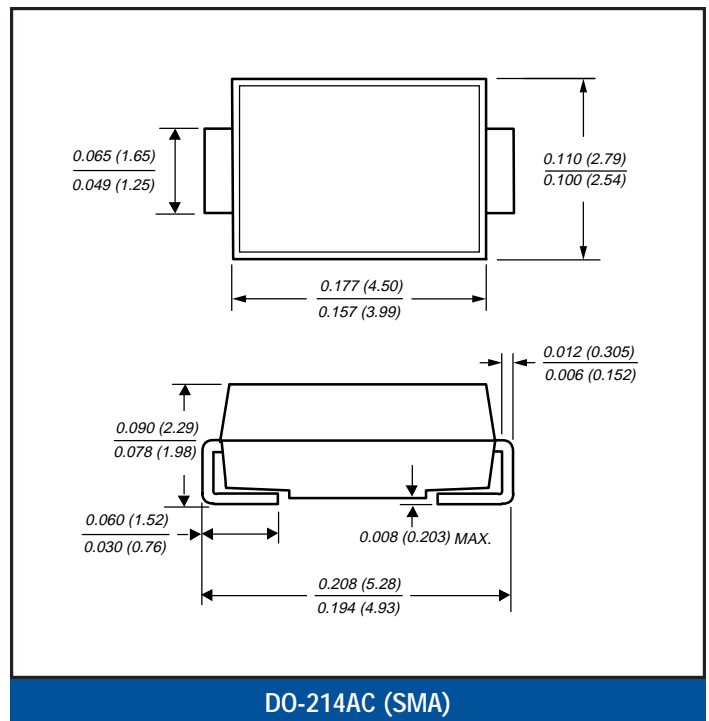
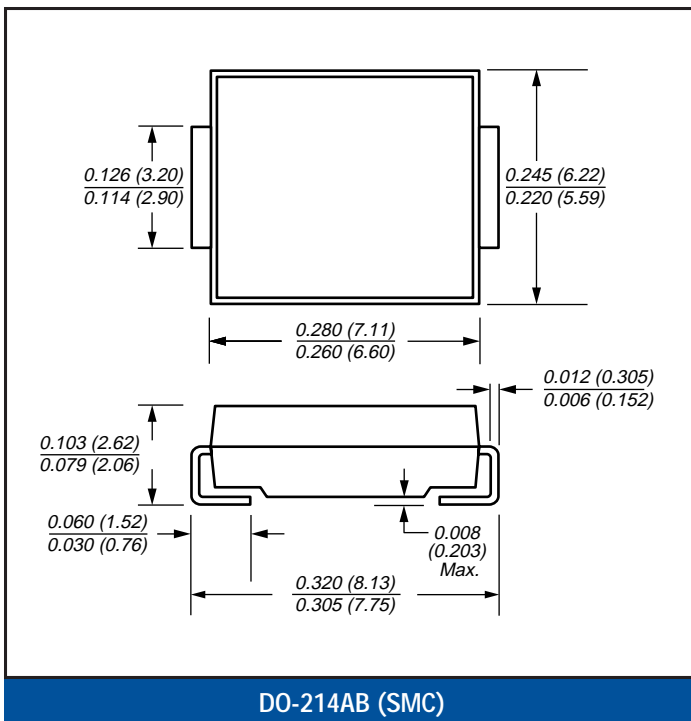
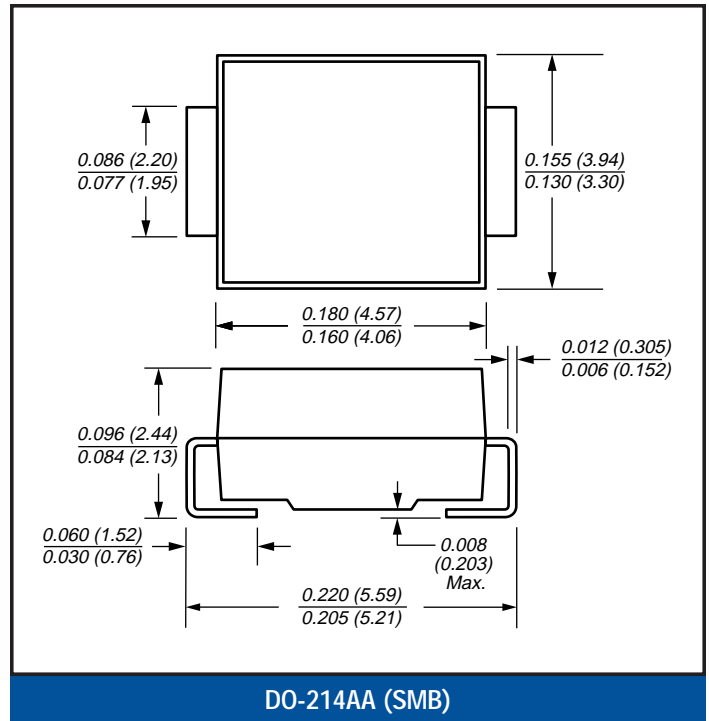
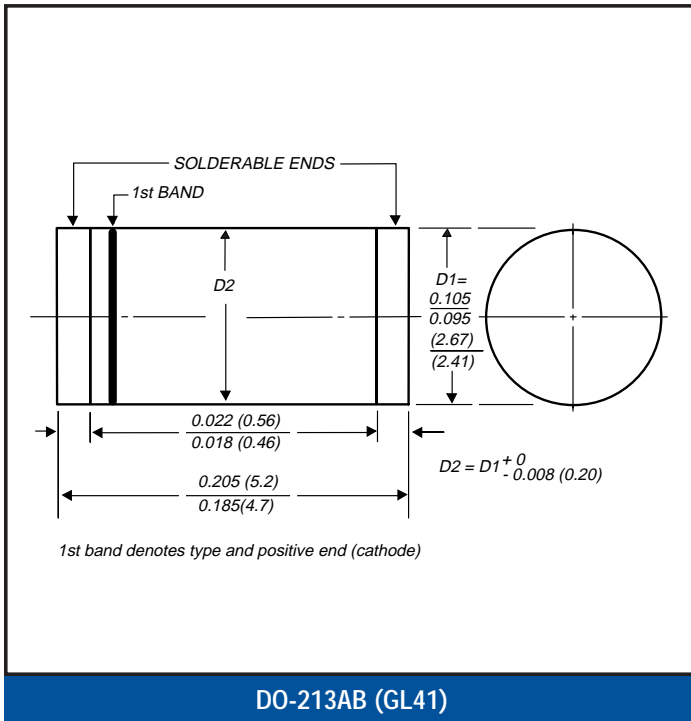

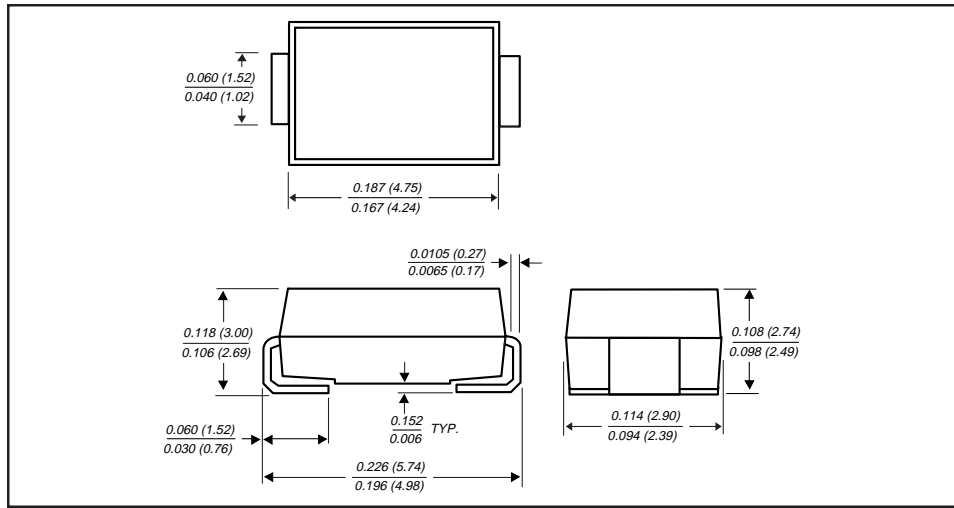

DO-214BA (GF1)

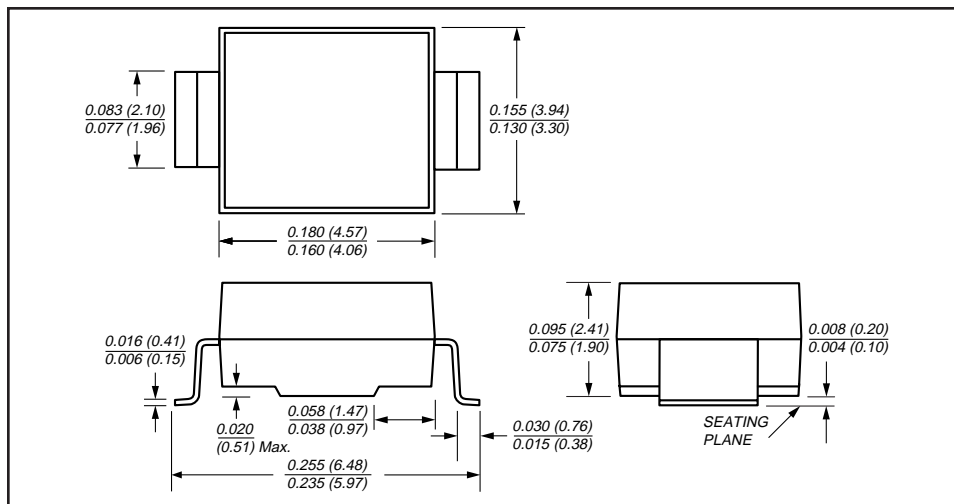

DO-215AA (SMBG GULL WING)

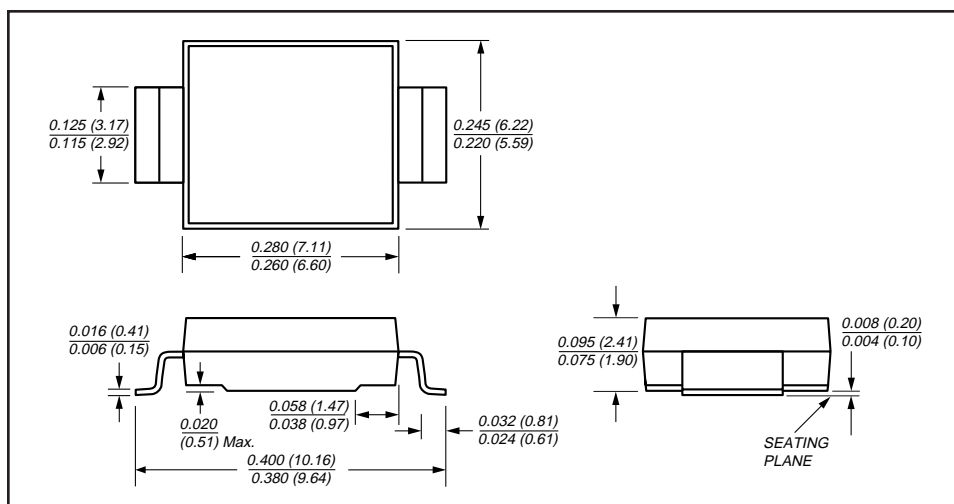

DO-215AB (SMCG GULL WING)

All dimensions in inches and (millimeters)

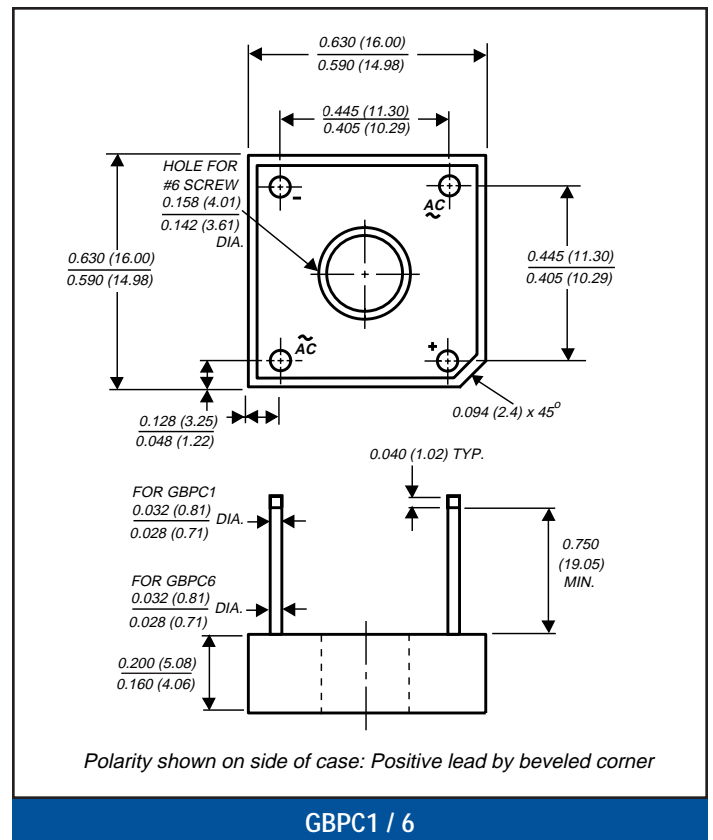
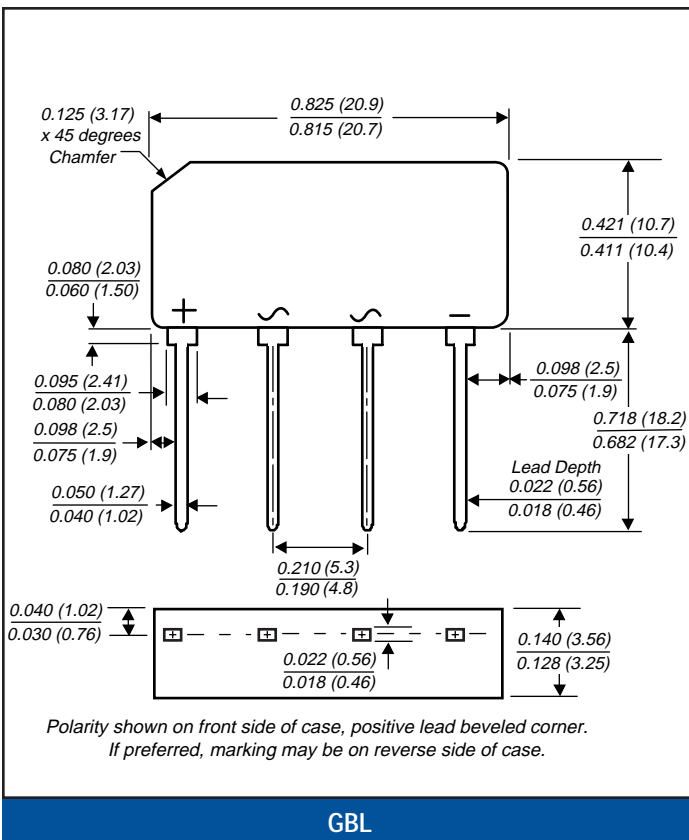
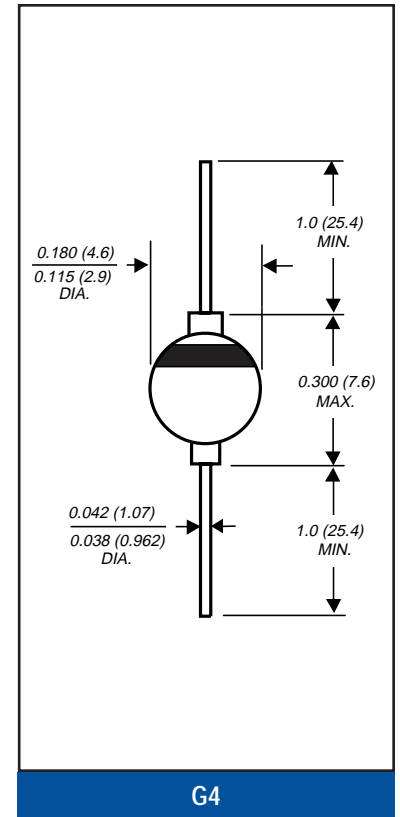
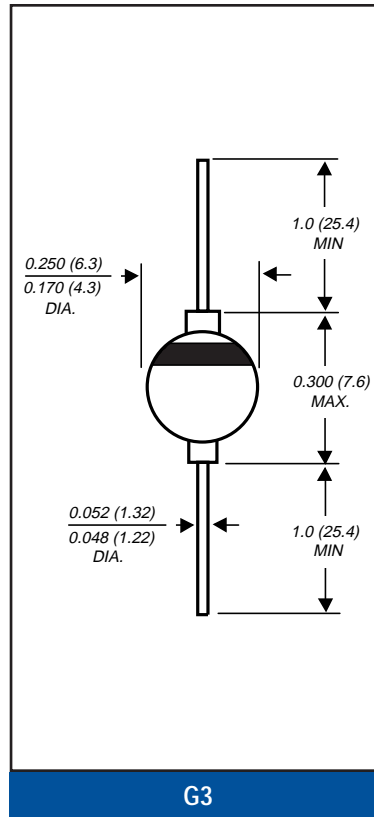
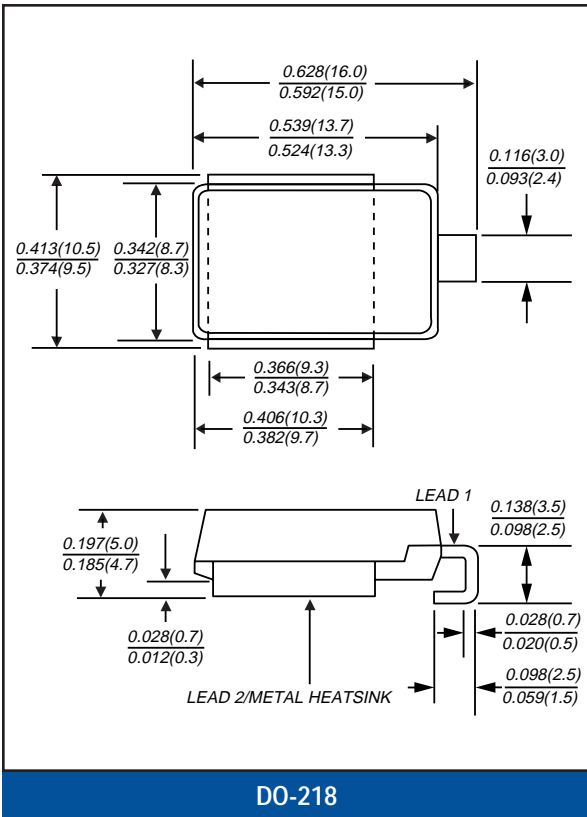

All dimensions in inches and (millimeters)

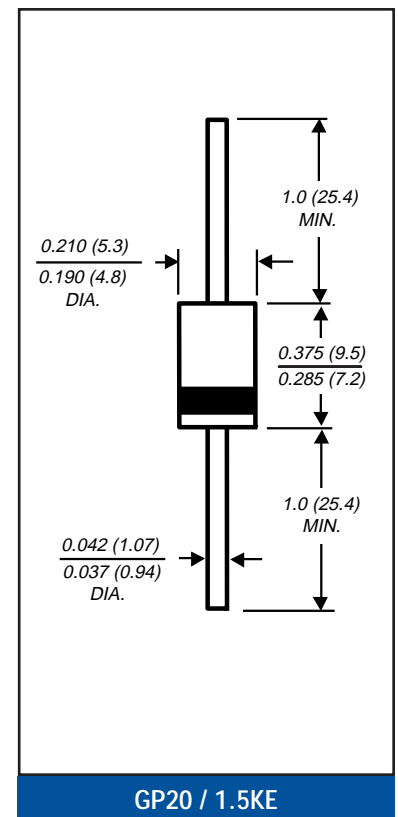
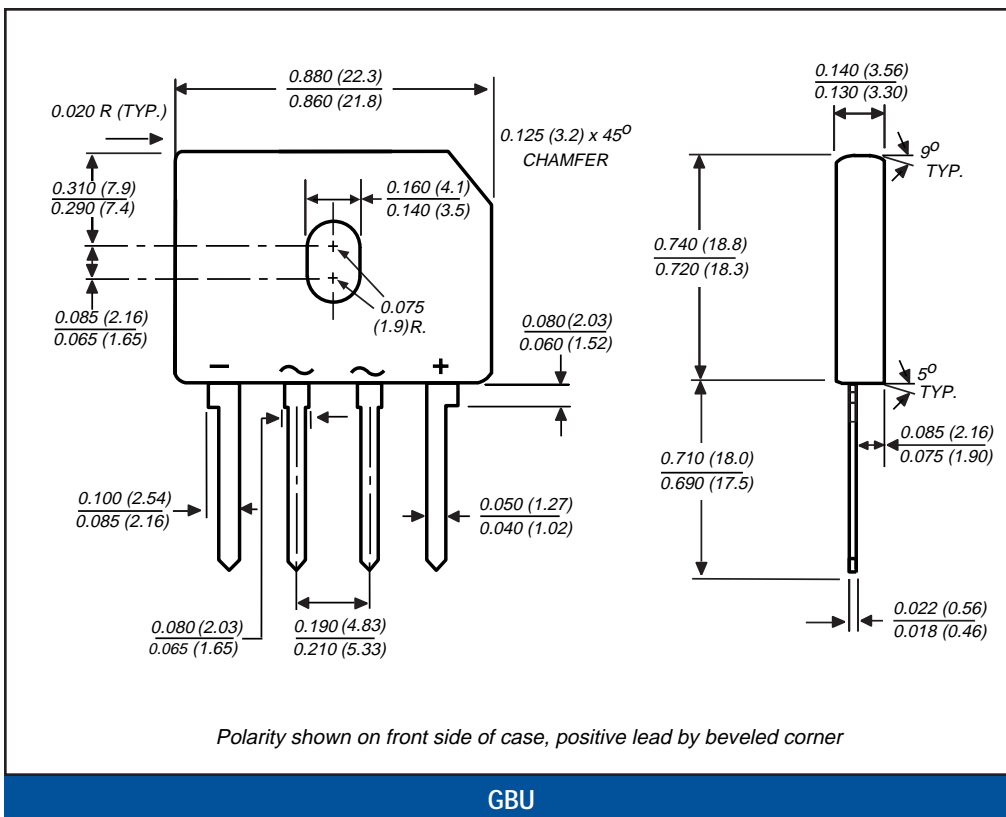
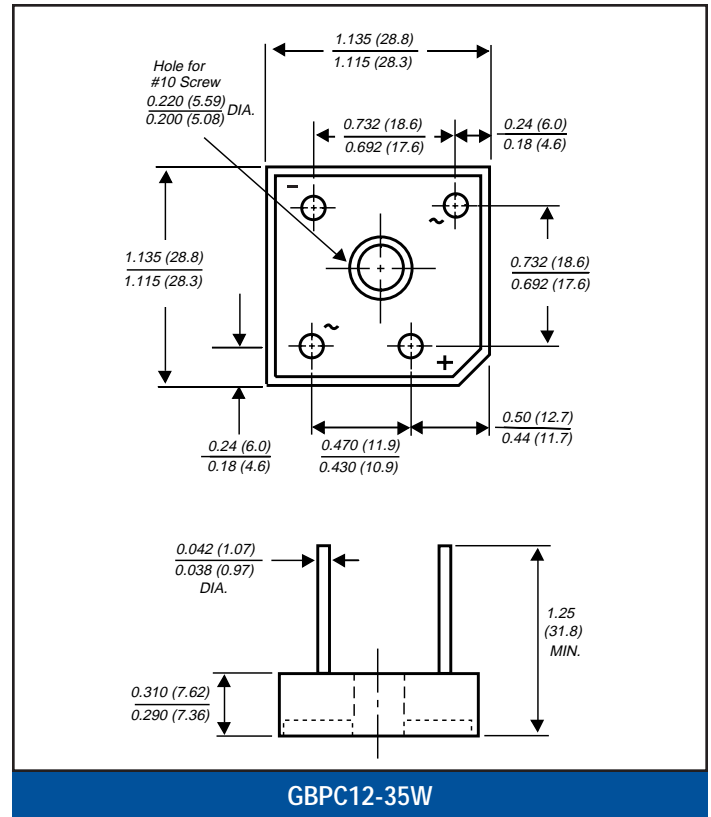
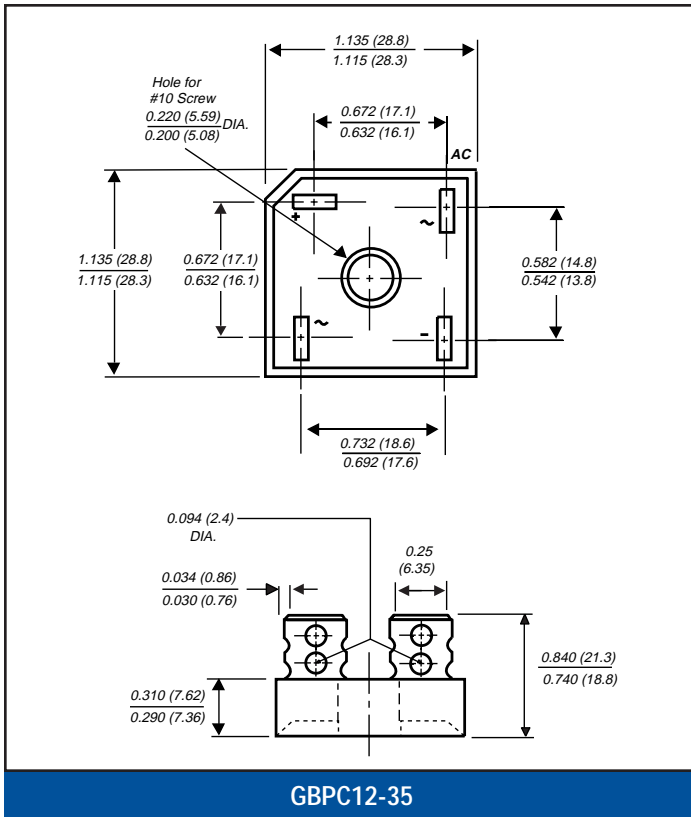

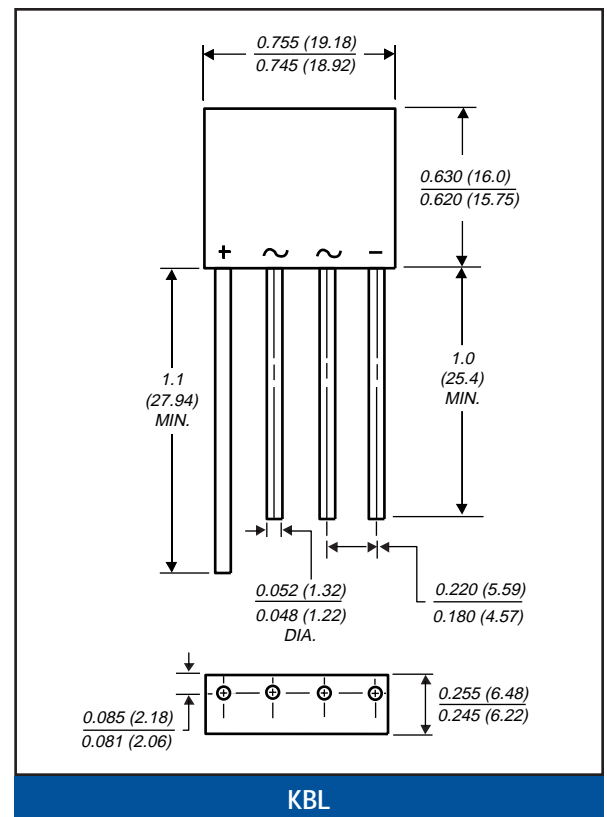
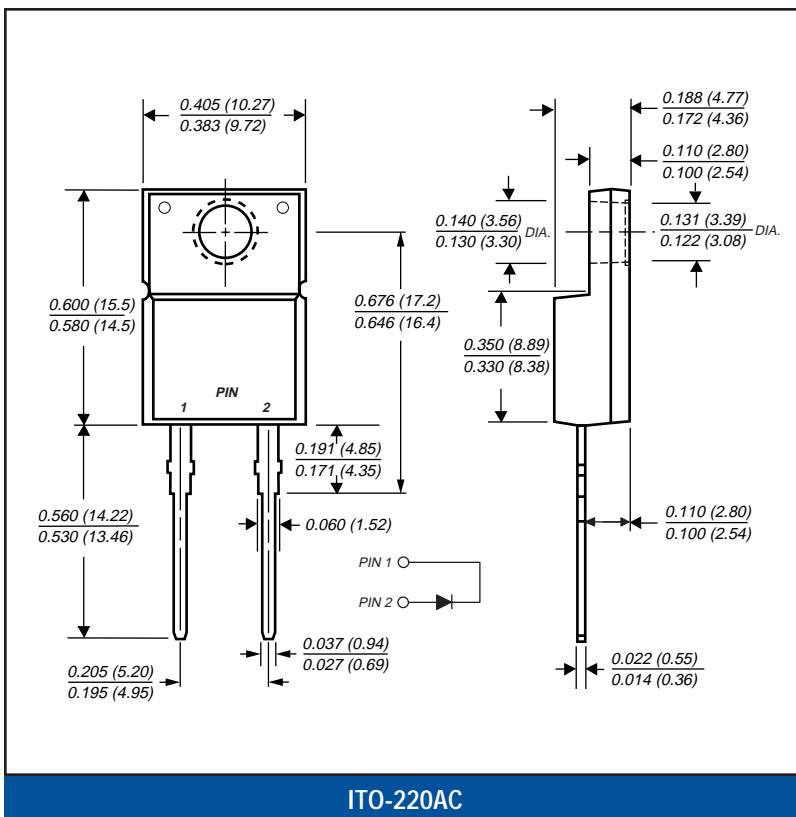
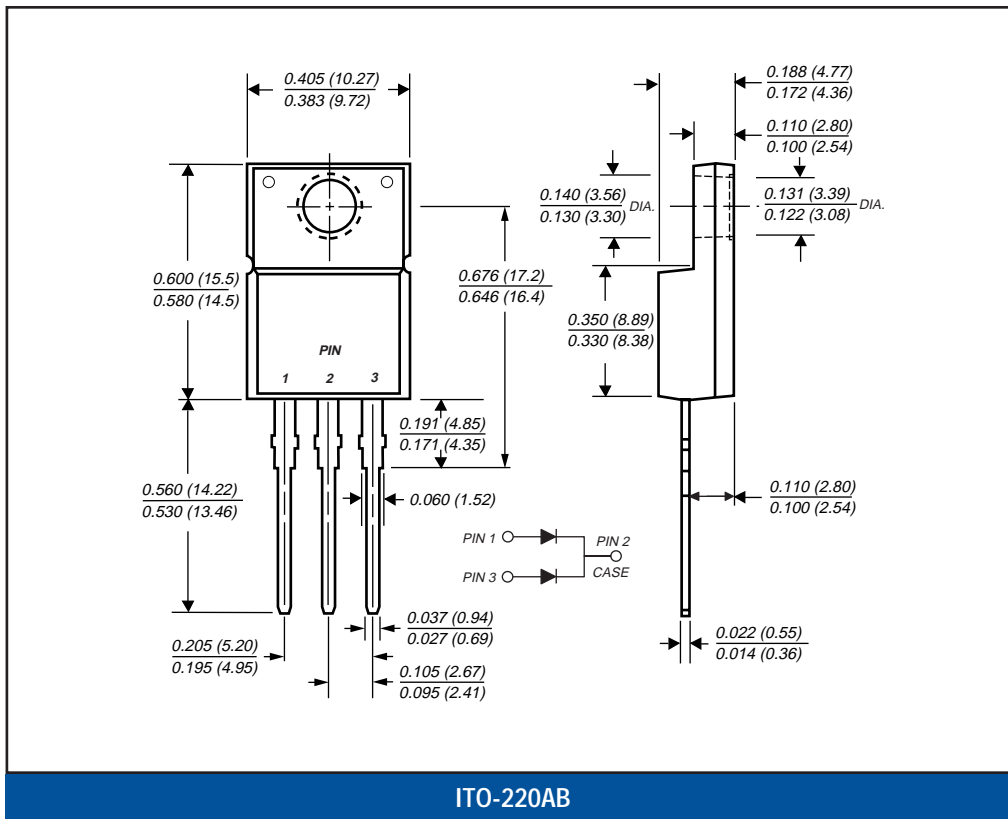

All dimensions in inches and (millimeters)

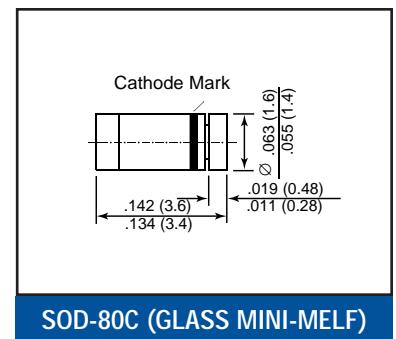
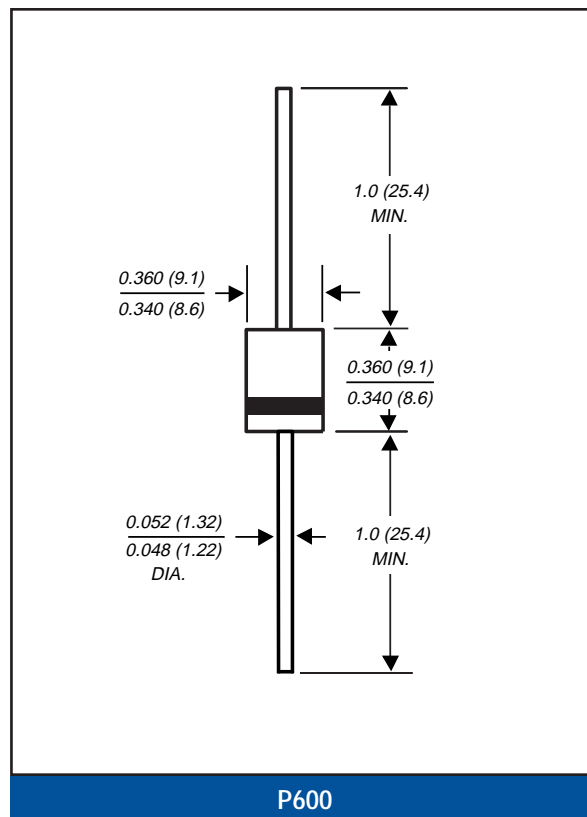
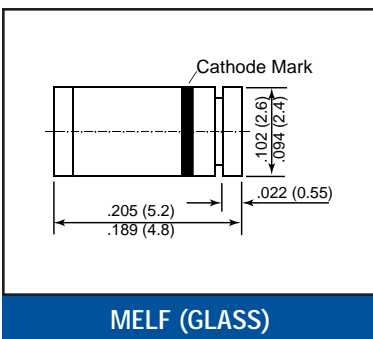
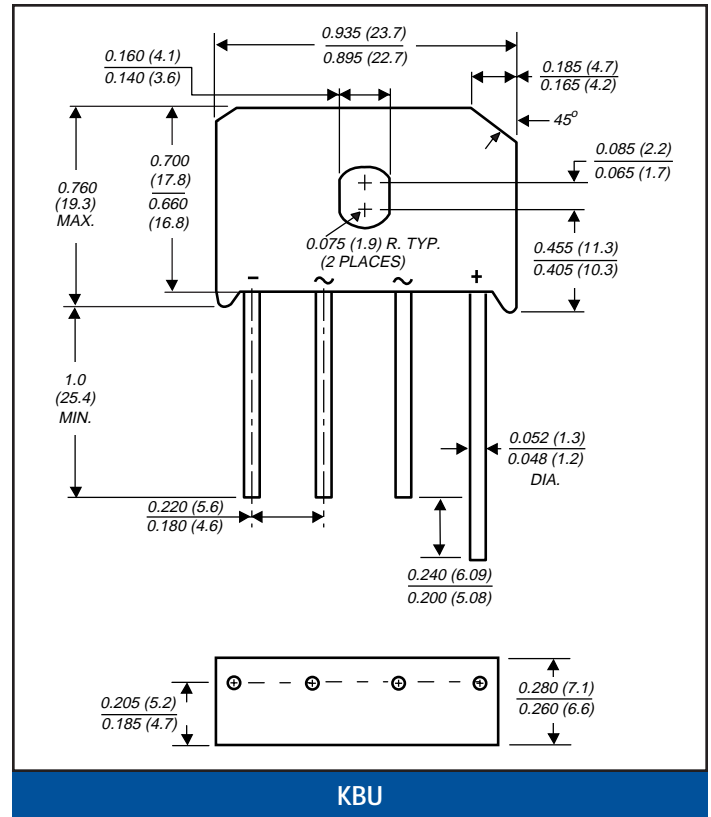
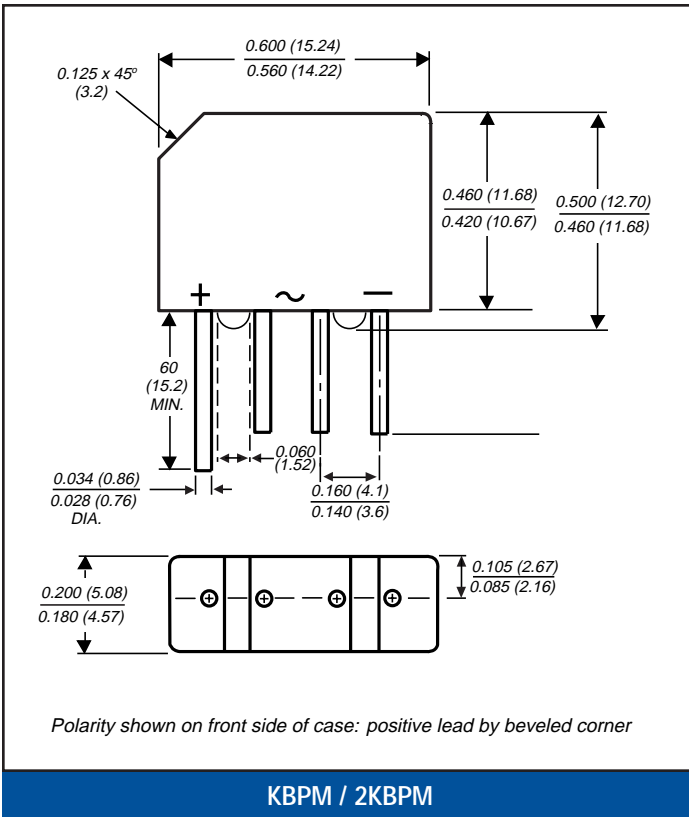

All dimensions in inches and (millimeters)

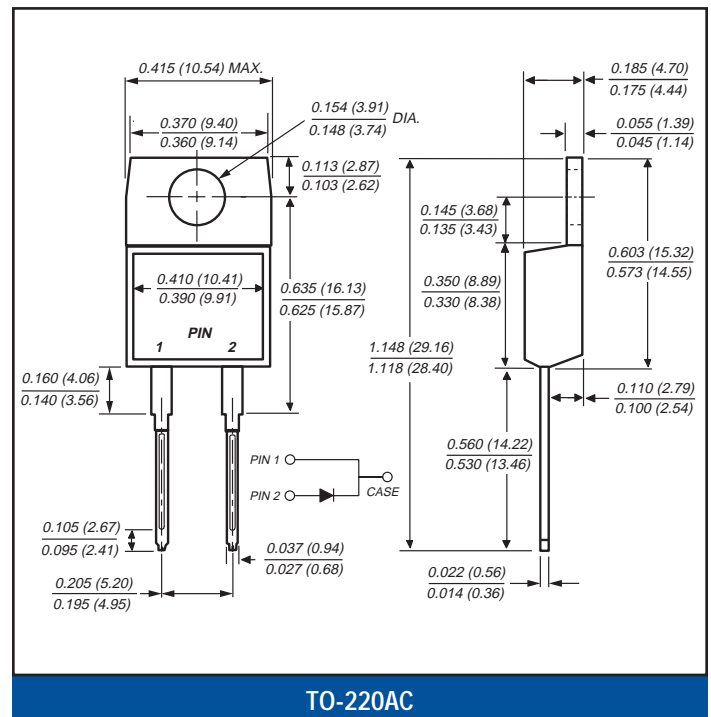
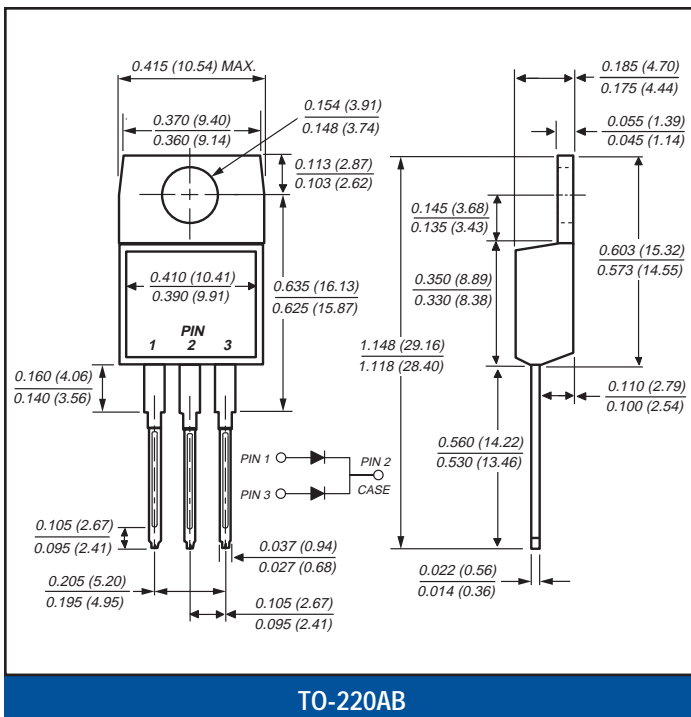
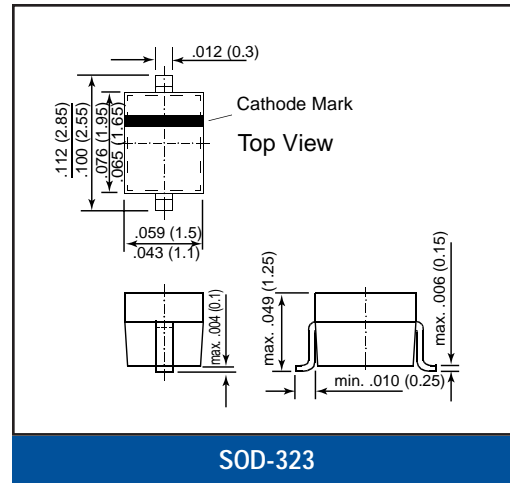
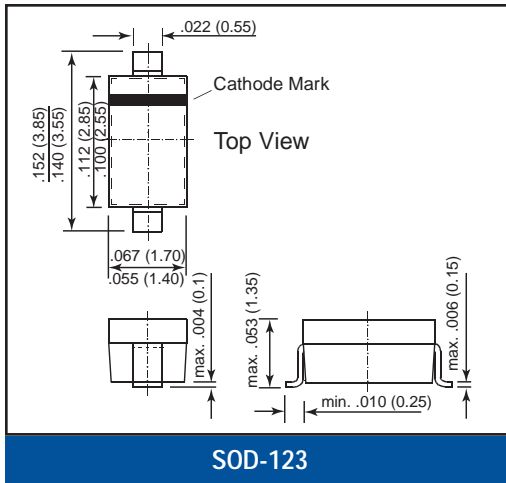

All dimensions in inches and (millimeters)

