

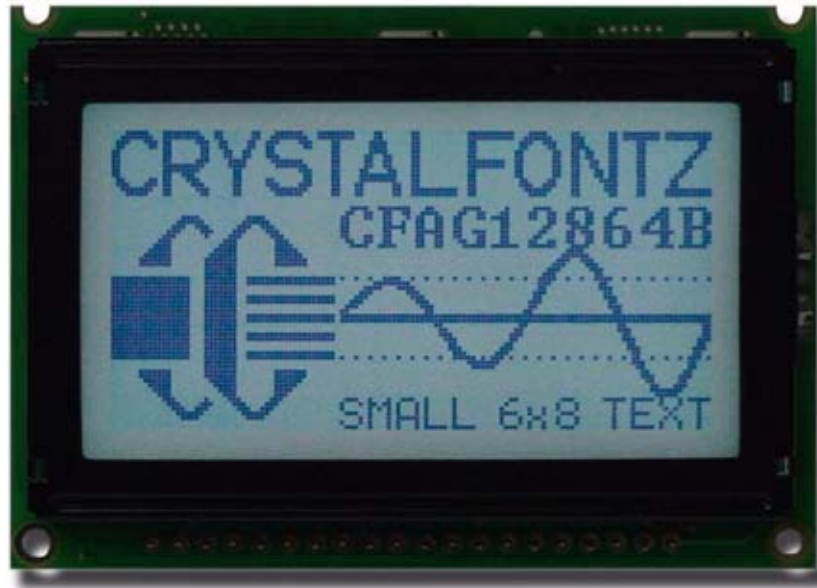

CrystalFontz America, Incorporated

GRAPHIC LCD MODULE SPECIFICATIONS



CrystalFontz Model Number	CFAG12864B-WGH-V
Hardware Version	Revision "A", September 2005
Data Sheet Version	Revision 1.0, December 2006
Product Pages	www.crystalfontz.com/products/12864b
Customer Name	
Customer Part Number	

CrystalFontz America, Incorporated

12412 East Saltese Avenue
Spokane Valley, WA 99216-0357

Phone: (888) 206-9720

Fax: (509) 892-1203

Email: techinfo@crystalfontz.com

URL: www.crystalfontz.com



REVISION HISTORY

HARDWARE	
2005/09/01	Current Hardware Version: vA

DATA SHEET	
2006/12/15	New Data Sheet: v1.0

The information in this publication is deemed accurate but is not guaranteed.

Company and product names mentioned in this publication are trademarks or registered trademarks of their respective owners.

© 2006 CrystalFontz America, Inc., 12412 East Saltese Avenue, Spokane Valley, WA 99212-0357 U.S.A.



CONTENTS

MAIN FEATURES	5
Module Classification Information	5
Ordering Information	6
MECHANICAL SPECIFICATIONS	6
Physical Characteristics	6
Module Outline Drawing	7
ELECTRICAL SPECIFICATIONS	8
System Block Diagram	8
Frame Ground	9
Driving Method	10
Absolute Maximum Ratings	10
DC Characteristics	10
Interface Pin Functions	11
Typical V_O Connections for Display Contrast	12
Samsung S6B0107/S6B0108 Controllers (Formerly KS0107B/KS0108B)	12
OPTICAL SPECIFICATIONS	13
Test Conditions and Definitions for Optical Characteristics	13
EL BACKLIGHT	16
Backlight Characteristics	16
EL Inverter	17
PRODUCT RELIABILITY	17
CARE AND HANDLING PRECAUTIONS	18
APPENDIX A: QUALITY ASSURANCE STANDARDS	20
APPENDIX B: SAMPLE CODE	24
Sources For Driver Libraries	24
C++ Initialization Example	24
APPENDIX C: SAMSUNG S6B0107 64 CH COMMON DRIVER	28
APPENDIX D: SAMSUNG S6B0108 64 CH SEGMENT DRIVER	29
APPENDIX E: CRYSTALFONTZ PN CFAIEL2 EL INVERTER SPECIFICATIONS	30



LIST OF FIGURES

Figure 1. Module Outline Drawing	7
Figure 2. System Block Diagram	8
Figure 3. Frame Ground (Back View of Module)	9
Figure 4. Typical V_O Connections for Display Contrast	12
Figure 5. Definition of Operation Voltage (V_{OP})	14
Figure 6. Definition of Response Time (T_r , T_f)	14
Figure 7. Definition of Horizontal and Vertical Viewing Angles ($CR > 2$)	15
Figure 8. 6:00 O'Clock and 12:00 O'Clock Viewing Angles	15
Figure 9. EL Backlight Connection Using Pin 19 and Pin 20	16
Figure 10. EL Inverter Photo (PN CFAIEL2)	17



MAIN FEATURES

- 128 x 64 dots graphic LCD module has a large display area in a compact 75.0 (W) x 52.7 (H) x 8.9 (D) millimeter package (2.95" (W) x 2.07" (H) x .35" (D)).
- White EL (ElectroLuminescent) backlight with STN positive transfective mode LCD. Displays dark dots on an illuminated light background). Requires an EL DC/AC Inverter (see [EL Inverter \(Pg. 17\)](#)).
- Sunlight readable.
- Built-in controllers Samsung PN S6B0107B (formerly Samsung PN KS0107B, see [APPENDIX C: SAMSUNG S6B0107 64 CH COMMON DRIVER \(Pg. 28\)](#)) and Samsung S6B0108B (formerly Samsung PN KS0108B, see [APPENDIX D: SAMSUNG S6B0108 64 CH SEGMENT DRIVER \(Pg. 29\)](#)).
- 8-bit parallel interface.
- Wide temperature operation: -20°C to +70°C.
- RoHS compliant.

MODULE CLASSIFICATION INFORMATION

CFA
①
G
②
128
③
64
④
B
⑤
-
W
⑥
G
⑦
H
⑧
-
V*
⑨

①	Brand	CrystalFontz America, Inc.
②	Display Type	G – Graphic
③	Number of Dots (Width)	128 dots
④	Number of Dots (Height)	64 dots
⑤	Model Identifier	B
⑥	Backlight Type & Color	W – EL, white
⑦	Fluid Type, Image (positive or negative), & LCD Glass Color	G – STN positive, light
⑧	Polarizer Film Type, Wide Temperature (WT) Range, & View Angle (O’Clock)	Transflective, WT, 6:00 ¹
⑨	Special Code	V – Built-in negative voltage generator (on the board) * – May have additional manufacturer's codes at this location.

¹For more information on View Angle, see [Definition of 6 O’Clock and 12:00 O’Clock Viewing Angles \(Pg. 15\)](#).



ORDERING INFORMATION

PART NUMBER	BUILT-IN NEGATIVE VOLTAGE GENERATOR	FLUID	LCD GLASS COLOR	IMAGE	POLARIZER FILM	BACKLIGHT
CFAG12864B-WGH-V	Yes	STN	light	positive	transflective	white EL lamp
<i>Additional variant (same form factor, different LCD mode or backlight):</i>						
CFAG12864B-TFH-V	Yes	FSTN	light	positive	transflective	white edge LEDs
CFAG12864B-TMI-V	Yes	STN	blue	negative	transmissive	white edge LEDs
CFAG12864B-WGH-N	Yes	STN	light	positive	transflective	white EL lamp
CFAG12864B-YYH-N	No	STN	yellow-green	positive	transflective	yellow-green edge LEDs
CFAG12864B-YYH-V	Yes	STN	yellow-green	positive	transflective	yellow-green edge LEDs

MECHANICAL SPECIFICATIONS

PHYSICAL CHARACTERISTICS

ITEM	SIZE
Number of Dots	128 x 264 dots
Module Dimensions	75.0 (W) x 52.7 (H) x 8.9 (D) mm
Viewing Area	60.0 (W) x 32.6 (H) mm
Active Area	55.0 (W) x 27.48 (H) mm
Dot Size	.39 (W) x .39 (H) mm
Dot Pitch	.43 (W) x .43 (H) mm
Weight	32 grams (typical)



MODULE OUTLINE DRAWING

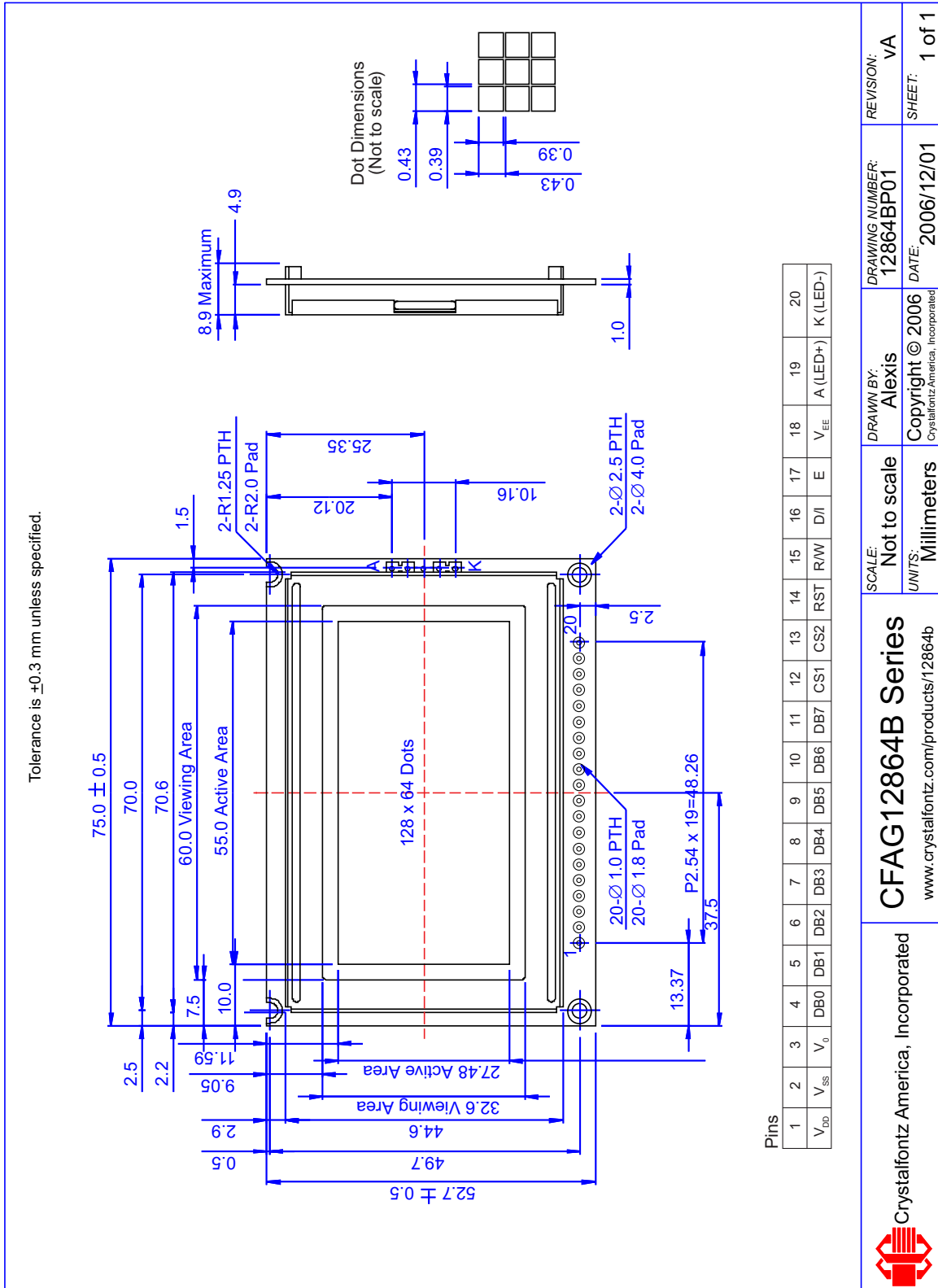
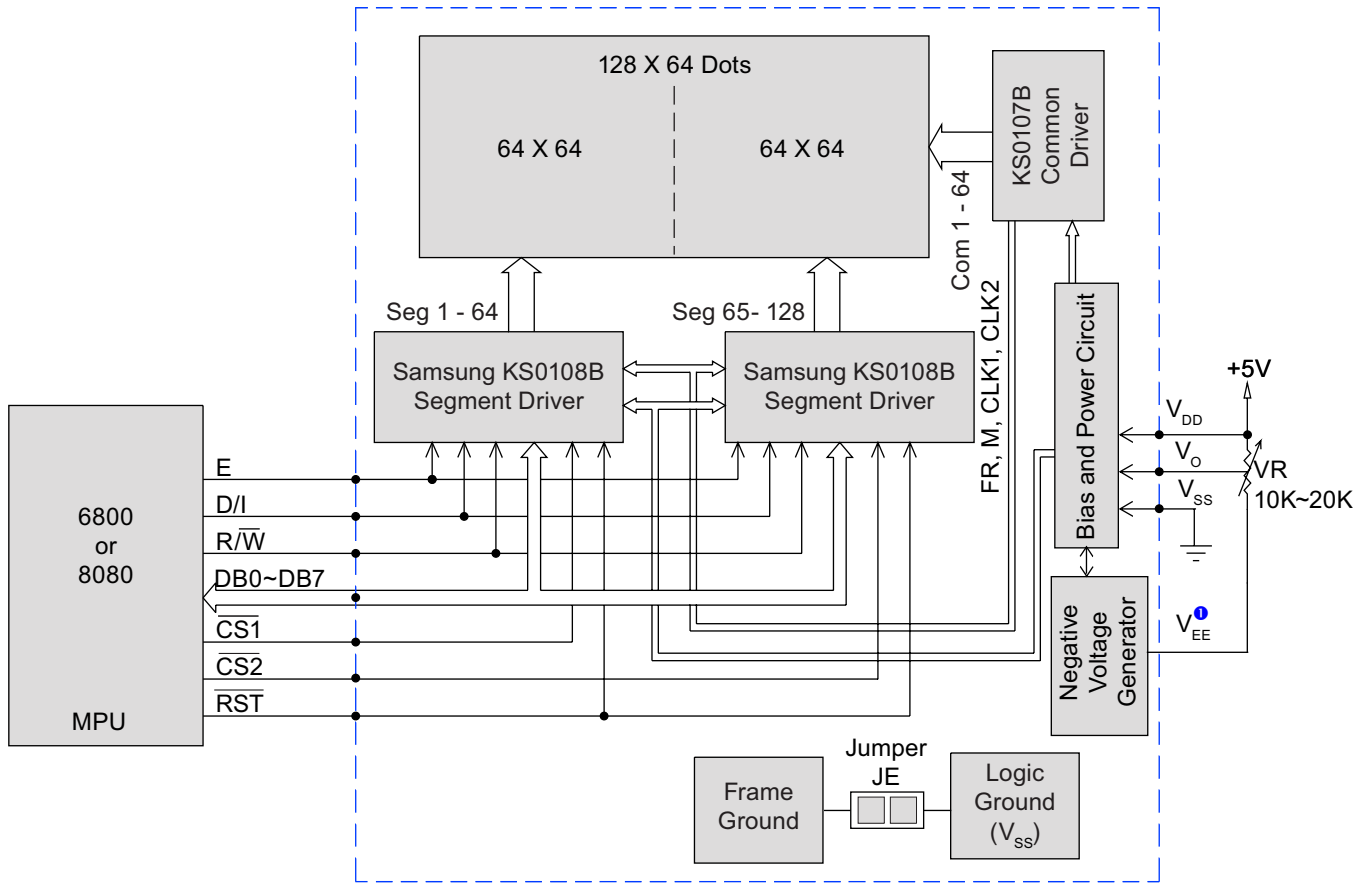

Figure 1. Module Outline Drawing



ELECTRICAL SPECIFICATIONS

SYSTEM BLOCK DIAGRAM



¹V_{EE} = output pin of on-board negative voltage generator

Figure 2. System Block Diagram



FRAME GROUND

Frame Ground (shown in the System Block Diagram above) is a trace that connects some of the bezel tabs. To connect Frame Ground to the Logic Ground (V_{SS} , Pin 2), use an "0805" package 0 ohm resistor to close jumper **JE**.

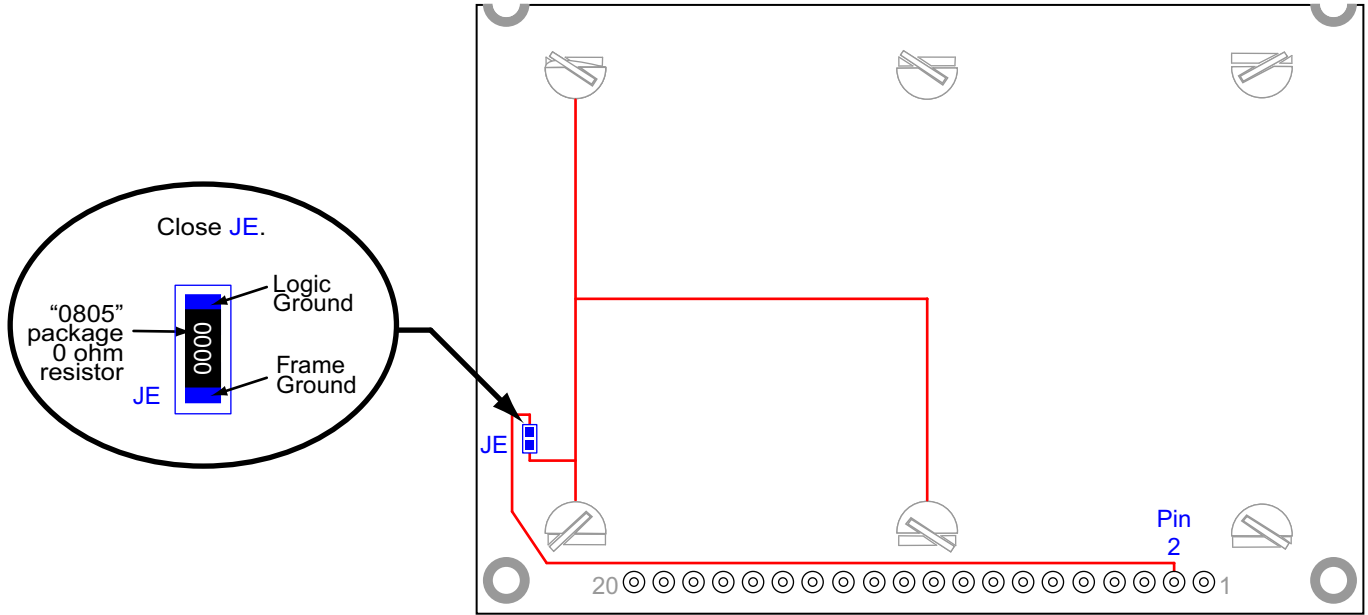

Figure 3. Frame Ground (Back View of Module)



DRIVING METHOD

DRIVING METHOD	SPECIFICATION
Duty	1/64
Bias	1/9

ABSOLUTE MAXIMUM RATINGS

ABSOLUTE MAXIMUM RATINGS	SYMBOL	MINIMUM	MAXIMUM
Operating Temperature	T_{OP}	-20°C	+70°C
Storage Temperature*	T_{ST}	-30°C	+80°C
Input Voltage	V_I	0	V_{DD}
Supply Voltage for Logic	V_{DD}	0	6.7v
Supply Voltage for LCD	$V_{DD}-V_O$		16.0v

**Note: Prolonged exposure at temperatures outside of this range may cause permanent damage to the module.*

DC CHARACTERISTICS

DC CHARACTERISTICS*	SYMBOL	MINIMUM	TYPICAL	MAXIMUM
Supply voltage for driving LCD	$V_{DD} - V_O$			+9.8v
			$T_A = -20^\circ\text{C}$	
			$T_A = +25^\circ\text{C}$	+8.0v
		+7.6v		
Logic Voltage	V_{DD}	+4.5v	+5.0v	+5.5v
Input High Voltage	V_{IH}	3.5v		V_{DD}
Input Low Voltage	V_{IL}	0 (V_{SS})		+0.8v
Supply Current (Logic only, not including backlight)	I_{DD}	1.5 mA		4.0 mA

**For more information, see [DC Characteristics on page 12 of Appendix D, S6B0108 64 CH Segment Driver for Dot Matrix LCD.](#)*



INTERFACE PIN FUNCTIONS

PIN	SIGNAL	LEVEL	DIRECTION	DESCRIPTION
1	V_{DD}	+5.0v	–	Supply voltage for logic
2	V_{SS}	0v	–	Ground
3	V_O	variable	–	Supply voltage for driving LCD $V_O = -3.0v$ typical at $V_{DD} = +5v$ which gives $V_{LCD} = (V_{DD} - V_O) = 8v$
4	DB0	H/L	I/O	Data bit 0
5	DB1	H/L	I/O	Data bit 1
6	DB2	H/L	I/O	Data bit 2
7	DB3	H/L	I/O	Data bit 3
8	DB4	H/L	I/O	Data bit 4
9	DB5	H/L	I/O	Data bit 5
10	DB6	H/L	I/O	Data bit 6
11	DB7	H/L	I/O	Data bit 7
12	$\overline{CS1}$	L	I	Chip select for controller #1 Columns 1 to 64 Chip select for controller #2 Columns 65 to 128
13	$\overline{CS2}$	L	I	Select Column 65 to Column 128
14	\overline{RST}	L	I	Controller reset signal
15	R/\overline{W}	H/L		Read/write selection input H: read (MPU←module) L: write (MPU→module)



PIN	SIGNAL	LEVEL	DIRECTION	DESCRIPTION
16	D/I	H/L	I	H: Data L: Instruction
17	E	H, H→L	I	Read/write enable signal H: read data is enabled by a high level H→L: write data is latched on the falling edge
18	V _{EE}	-5v	O	Negative voltage output
19	A (LED+)			Supply voltage for LED "A" (anode) or "+" of LED backlight
20	K (LED+)			Supply voltage for LED "K" (cathode or kathode for German and original Greek spelling) or "-" of LED backlight

For Backlight connections, please refer to [EL BACKLIGHT \(Pg. 16\)](#).

TYPICAL V_O CONNECTIONS FOR DISPLAY CONTRAST

Adjust V_O to -3.0v (V_{LCD} = 8.0v) as an initial setting. When the module is operational, readjust V_O for optimal display appearance.

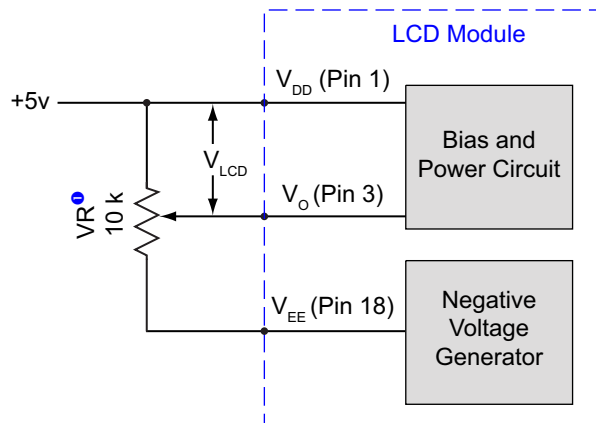

• Use external control to adjust for optimal display appearance.

Figure 4. Typical V_O Connections for Display Contrast

SAMSUNG S6B0107/S6B0108 CONTROLLERS (FORMERLY KS0107B/ KS0108B)

The CFAG12864B-WGH-V uses two Samsung controllers: S6B0107 64 channel common driver and a S6B0108 64 channel segment driver. The previous part number for the Samsung S6B0107 driver was "KS0107B". The previous part number for the Samsung S6B0108 driver was "KS6B108".



For your reference, the most recent versions (July 2001) of the Samsung driver specifications are included as appendixes in this Data Sheet: Samsung S6B0107 64CH Common Driver for Dot Matrix LCD and S6B0108 64CH Segment Driver For Dot Matrix LCD.

Here are links to some of the commonly used sections:

- For DC characteristics, see [page 12 of Appendix D, "DC Characteristics"](#).
- For functional description, see [page 17 of Appendix C, "Functional Description"](#).
- For MPU interface timing characteristics (read and write), see [page 15 of Appendix D, "MPU Interface"](#).
- For display control instruction, see [page 21 of Appendix D, "Display Control Instruction"](#).

OPTICAL SPECIFICATIONS

ITEM	SYMBOL	CONDITION	MINIMUM	TYPICAL	MAXIMUM
View Angle (Vertical, Horizontal)	(V) θ	CR \geq 2	20°		40°
	(H) ϕ	CR \geq 2	-30°		+30°
Contrast Ratio	CR			3	
LCD Response Time*	T rise	Ta = 25°C		150 ms	200 ms
	T fall	Ta = 25°C		150 ms	200 ms
*Response Time: The amount of time it takes a liquid crystal cell to go from active to inactive or back again.					

TEST CONDITIONS AND DEFINITIONS FOR OPTICAL CHARACTERISTICS

Test Conditions

- Operating Voltage (V_{LCD}): V_{OP}
- Viewing Angle
 - Vertical (V) θ : 0°
 - Horizontal (H) ϕ : 0°
- Frame Frequency: 64 Hz (nominal)
- Driving Waveform: 1/64 Duty, 1/9 Bias
- Ambient Temperature (Ta): 25°C



Definition Operation Voltage (V_{op})

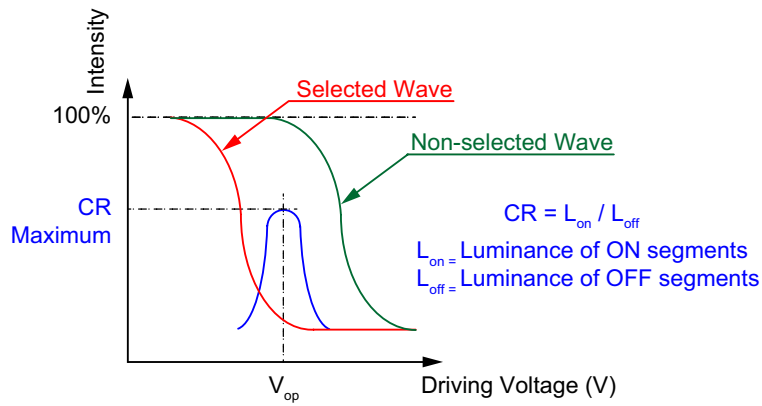

Figure 5. Definition of Operation Voltage (V_{OP})

Definition of Response Time (T_r , T_f)

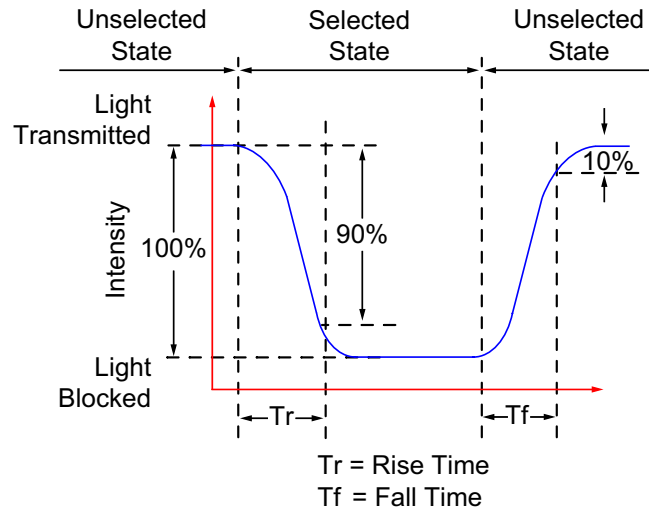

Figure 6. Definition of Response Time (T_r , T_f)



Definition of Vertical and Horizontal Viewing Angles (CR>2)

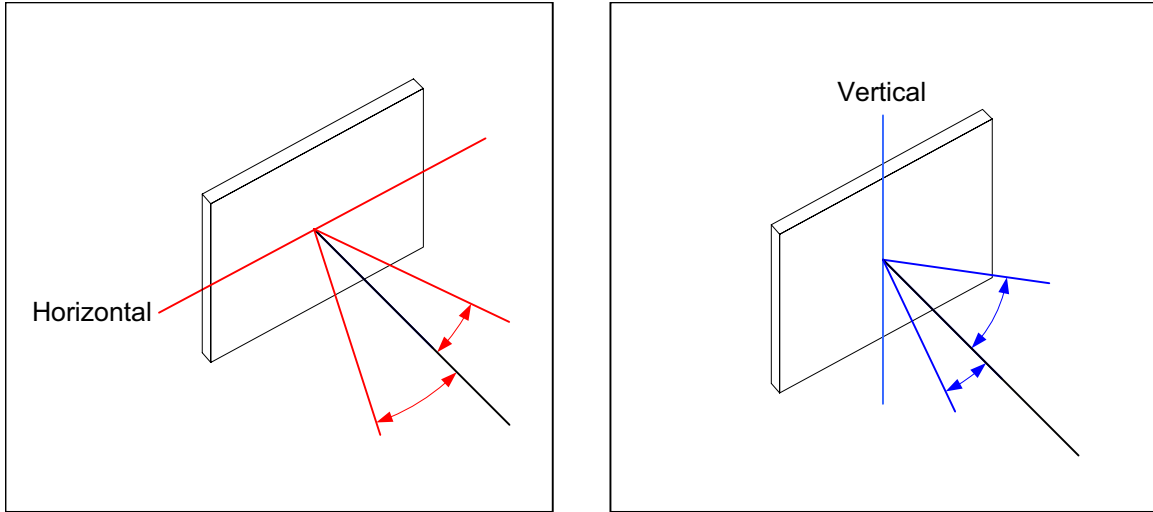

Figure 7. Definition of Horizontal and Vertical Viewing Angles (CR>2)

Definition of 6 O'Clock and 12:00 O'Clock Viewing Angles

A 6:00 o'clock viewing angle is a bottom viewing angle like what you would see when looking at a cell phone or calculator. A 12:00 o'clock viewing angle is a top viewing angle like what you would see when looking at the gauges in a golf cart or airplane.

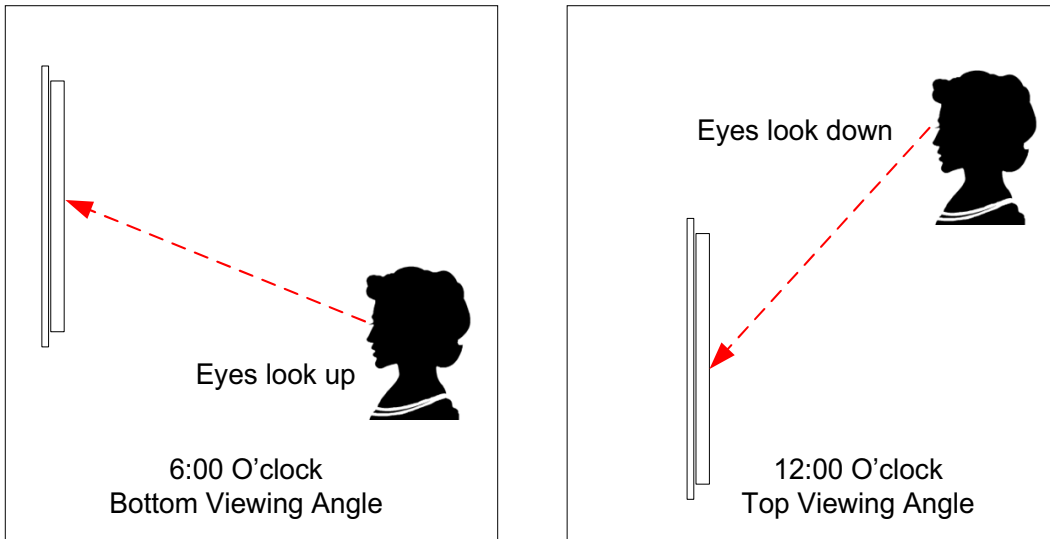

Figure 8. 6:00 O'Clock and 12:00 O'Clock Viewing Angles



EL BACKLIGHT

You can connect the CFAG12864B-WGH-V backlight by one of these two methods:

- Solder leads from your PCB's circuit to the "A" and "K" connectors on the right edge of the display (glass facing up).
- Make connections to your PCB using Pins 19 (A (LED+)) and 20 (K (LED+)) on the display module's connector.

BACKLIGHT CHARACTERISTICS

EL Backlight Characteristics			
<i>Dark dots on illuminated light background</i>			
PARAMETER	MINIMUM	TYPICAL	MAXIMUM
Drive Voltage (V_{MAX})		100 V_{RMS}	
Drive Wave (F_{MAX})		400 Hz	
Luminous Intensity* (IV) 110v / 400 Hz		60 cd/m^2	
Chromaticity	x	0.330	
	y	0.365	

**Direct measurement of backlight—the backlight is not measured through the LCD.*

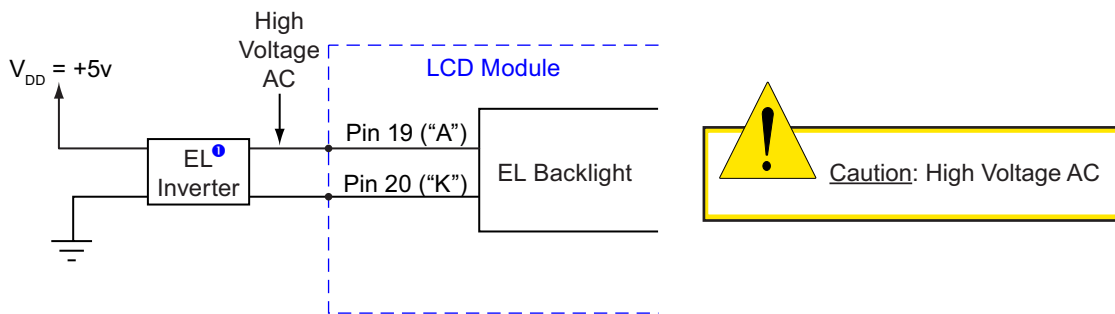

- Crystalfontz PN CFAIEL2 or other EL inverter. The EL inverter may be built onto your PCB or purchased as a separate component.

Figure 9. EL Backlight Connection Using Pin 19 and Pin 20



EL INVERTER

The CFAG12864B-WGH-V has an EL backlight. You may build a DC to AC power EL inverter onto your PCB or purchase one as a separate component. To purchase the CrystalFontz EL Inverter, (PN CFAIEL2) see [CFAIEL2](#) on our website. For CFAIEL2 specifications, see [APPENDIX E: CRYSTALFONTZ PN CFAIEL2 EL INVERTER SPECIFICATIONS \(Pg. 30\)](#).

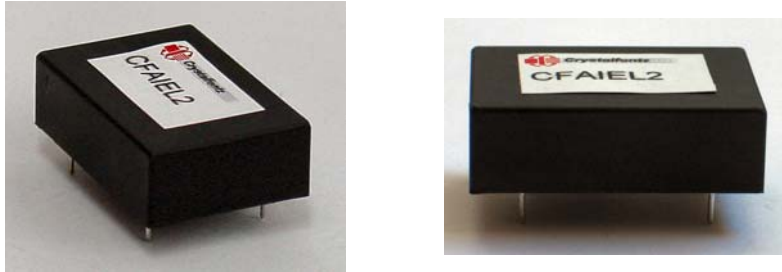

Figure 10. EL Inverter Photo (PN CFAIEL2)

PRODUCT RELIABILITY

ITEM	SPECIFICATION
Module, excluding backlight.	50,000 to 100,000 hours (typical)
EL Lamp Backlight (110v / 400 Hz) <i>* Driving the EL backlight brighter (higher voltage and/or higher frequency) will make the backlight grow dim faster.</i>	5,000 hours half-life



CARE AND HANDLING PRECAUTIONS

For optimum operation of the module and to prolong its life, please follow the precautions described below.

ESD (ELECTRO-STATIC DISCHARGE)

The circuitry is industry standard CMOS logic and susceptible to ESD damage. Please use industry standard anti-static precautions as you would for any other PCB such as expansion cards or motherboards.

DESIGN AND MOUNTING

- The exposed surface of the LCD “glass” is actually a polarizer laminated on top of the glass. To protect the polarizer from damage, the CFAG12864B-WGH-V ships with a protective film over the polarizer. Please peel off the protective film slowly. Peeling off the protective film abruptly may generate static electricity.
- The polarizer is made out of a soft plastic and is easily scratched or damaged. To protect the polarizer from damage, place a transparent plate (for example, acrylic, polycarbonate, or glass) in front of the CFAG12864B-WGH-V leaving a small gap between the plate and the display surface. We recommend GE HP-92 Lexan, which is readily available and works well.
- Do not disassemble or modify the module.
- Do not modify the mounting tab of the metal bezel or make connections to it.
- Solder only to the I/O terminals. Use care when removing solder—it is possible to damage the PCB.
- Do not reverse polarity to the power supply connections. Reversing polarity will immediately ruin the module.

AVOID SHOCK, IMPACT, TORQUE, AND TENSION

- Do not expose the module to strong mechanical shock, impact, torque, and tension.
- Do not drop, toss, bend, or twist the module.
- Do not place weight or pressure on the module.

IF LCD PANEL BREAKS

- If the LCD panel breaks, be careful to not get the liquid crystal fluid in your mouth or eyes.
- If the liquid crystal fluid touches your skin, clothes, or work surface, wash it off immediately using soap and plenty of water.
- Do not eat the LCD panel.

CLEANING

- The polarizer (laminated to the glass) is made out of a soft plastic and is easily scratched or damaged. Be very careful when you clean the polarizer. Use the removable protective film to remove smudges (for example, fingerprints) and any foreign matter.
- Do not clean the polarizer with liquids. Do not wipe the polarizer with any type of cloth or swab (for example, Q-tips). Damage will be especially obvious on “negative” modules (module that appear dark when “off”).



OPERATION

- We do not recommend connecting this module to a PC's parallel port as an "end product". This module is not "user friendly" and connecting them to a PC's parallel port is often difficult, frustrating, and can result in a "dead" display due to mishandling. For more information, see our forum thread at <http://www.crystalfontz.com/forum/showthread.php?s=&threadid=3257>.
- Your circuit should be designed to protect the module from ESD and power supply transients.
- Observe the operating temperature limitations: a minimum of -20°C to +70°C maximum with minimal fluctuations. Operation outside of these limits may shorten the life and/or harm the display.
 - At lower temperatures of this range, response time is delayed.
 - At higher temperatures of this range, display becomes dark. (You may need to adjust the contrast.)
- Adjust backlight brightness so the display is readable but not too bright. Dim or turn off the backlight during periods of inactivity to conserve the white EL backlight lifetime.
- Operate away from dust, moisture, and direct sunlight.

STORAGE

- Store in an ESD-approved container away from dust, moisture, and direct sunlight.
- Observe the storage temperature limitations: a minimum of -30°C minimum to +80°C maximum with minimal fluctuations. Rapid temperature changes can cause moisture to form, resulting in permanent damage.
- Do not allow weight to be placed on the modules while they are in storage.



APPENDIX A: QUALITY ASSURANCE STANDARDS

INSPECTION CONDITIONS

- Environment
 - Temperature: $25\pm 5^{\circ}\text{C}$
 - Humidity: 30~85% RH
- For visual inspection of active display area
 - Source lighting: two 20 Watt or one 40 Watt fluorescent light
 - Display adjusted for best contrast
 - Viewing distance: 30 ± 5 cm (about 12 inches)
 - Viewable angle: inspect at 45° angle of vertical line right and left, top and bottom

DEFINITION OF ACTIVE AREA AND VIEWING AREA

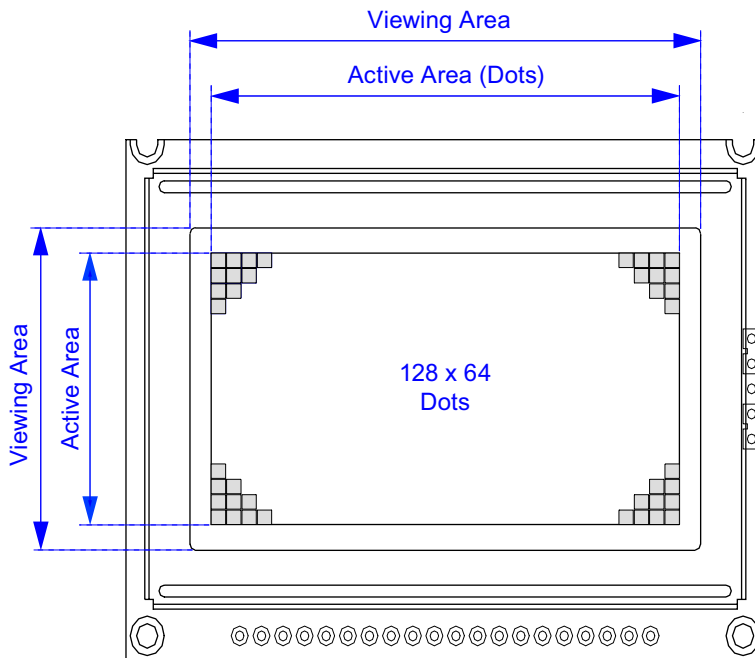



ACCEPTANCE SAMPLING

DEFECT TYPE	AQL*
Major	≤.65%
Minor	<1.0%
* Acceptable Quality Level: maximum allowable error rate or variation from standard	

DEFECTS CLASSIFICATION

Defects are defined as:

- Major Defect: results in failure or substantially reduces usability of unit for its intended purpose
- Minor Defect: deviates from standards but is not likely to reduce usability for its intended purpose

ACCEPTANCE STANDARDS

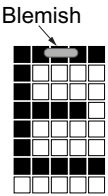
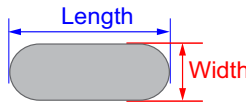
#	DEFECT TYPE	CRITERIA		MAJOR / MINOR	
1	Electrical defects	1. No display, display malfunctions, or shorted segments. 2. Current consumption exceeds specifications.		Major	
2	Viewing area defect	Viewing area does not meet specifications. (See Inspection Conditions (Pg. 20) .)		Major	
3	Contrast adjustment defect	Contrast adjustment fails or malfunctions.		Major	
4	Blemishes or foreign matter on display segments		<i>Defect Size</i> ≤0.3 mm	<i>Acceptable Qty</i> 3	Minor
			≤2 defects within 10 mm of each other		
5	Blemishes or foreign matter outside of display segments	Defect Size = (Width + Length)/2 	<i>Defect Size</i> ≤0.15 mm	<i>Acceptable Qty</i> Ignore	Minor
			0.15 to 0.20 mm	3	
			0.20 to 0.25 mm	2	
			0.25 to 0.30 mm	1	

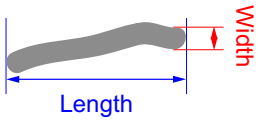
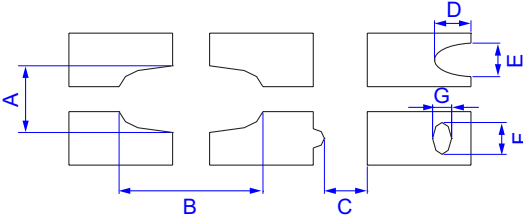

#	DEFECT TYPE	CRITERIA			MAJOR / MINOR
6	Dark lines or scratches in display area 	<i>Defect Width</i>	<i>Defect Length</i>	<i>Acceptable Qty</i>	Minor
		≤0.03 mm	≤3.0 mm	3	
		0.03 to 0.05	≤2.0 mm	2	
		0.05 to 0.08	≤2.0 mm	1	
		0.08 to 0.10	≤3.0 mm	0	
		≥0.10	>3.0 mm	0	
7	Bubbles between polarizer film and glass	<i>Defect Size</i>	<i>Acceptable Qty</i>	Minor	
		≤2.0 mm	Ignore		
		0.20 to 0.40 mm	3		
		0.40 to 0.60 mm	2		
		≥0.60 mm	0		
8	Display pattern defect 	<i>Dot Size</i>	<i>Acceptable Qty</i>	Minor	
		$((A+B)/2) \leq 0.2$ mm	≤3 total defects ≤2 pinholes per digit		
		C > 0 mm			
		$((D+E)/2) \leq 0.25$ mm			
		$((F+G)/2) \leq 0.25$ mm			
9	Backlight defects	1. Light fails or flickers. (Major) 2. Color and luminance do not correspond to specifications. (Major) 3. Exceeds standards for display's blemishes or foreign matter (see test 5, Pg. 21), and dark lines or scratches (see test 6, Pg. 22). (Minor)			See list ←
10	PCB defects	1. Oxidation or contamination on connectors.* 2. Wrong parts, missing parts, or parts not in specification.* 3. Jumpers set incorrectly. (Minor) 4. Solder (if any) on bezel, LED pad, zebra pad, or screw hole pad is not smooth. (Minor) *Minor if display functions correctly. Major if the display fails.			See list ←



#	DEFECT TYPE	CRITERIA	MAJOR / MINOR
11	Soldering defects	1. Unmelted solder paste. 2. Cold solder joints, missing solder connections, or oxidation.* 3. Solder bridges causing short circuits.* 4. Residue or solder balls. 5. Solder flux is black or brown. *Minor if display functions correctly. Major if the display fails.	Minor



APPENDIX B: SAMPLE CODE

SOURCES FOR DRIVER LIBRARIES

Graphic LCD driver libraries may save you a lot of time and help you develop a more professional product. Two library sources are [RAMTEX](#) and [easyGUI](#).

C++ INITIALIZATION EXAMPLE

Below is an example of an initialization sequence based on Atmel's ATmega32.

```
//=====
// LOW_LCD.C: Low-level lcd display routines.
// Samsung KS0107+KS0108 (S6B0107+S6B0108) LCD Controller
// Atmel ATmega32 processor @ 16MHz
// WinAVR / AVR GCC + Atmel AVR Studio
// Written by Brent A. Crosby
// Copyright 2005, CrystalFontz America, Inc. http://www.crystalfontz.com
//=====
#include <avr/io.h>
#include <avr/iom32.h>
#include <string.h>
#include <avr/delay_x.h>
#include "typedefs.h"
#include "utils.h"
#include "low_lcd.h"
//=====
//This is the display memory.
ubyte
    display[8][128]; //1024 bytes
//=====
void write_both_lcd_control_registers(ubyte data)
{
    //We need to wait until both controller's busy bits are clear.
    //Talk to the status (instruction) register.
    //(Must happen 140nS before the RISING edge of E.)
    PORTC&=~PORTC1_LCD_DI;
    //Tell the LCD we are going to be reading it
    //(Must happen 140nS before the RISING edge of E.)
    PORTC|=PORTC6_LCD_RW;
    //Talk to the left controller only
    //(Must happen 140nS before the RISING edge of E.)
    PORTC&=~PORTC0_LCD_CS1;
    PORTD|=PORTD6_LCD_CS2;
    //Make port A high-impedance
    DDRA=0x00;
    //Enable the selected controller's read data onto the port
    PORTC|=PORTC7_LCD_E;
    //The data is not valid for 320nS
    _delay_cycles(4); //375nS
}
```



```
//Wait for the busy bit to drop
while(PINA&0x80);
//Terminate the read
PORTC&=~PORTC7_LCD_E;

//Talk to the right controller only
PORTC|=PORTC0_LCD_CS1; //125nS
PORTD&=~PORTD6_LCD_CS2; //125nS
//(Must happen 140nS before the RISING edge of E.)
//(E LOW pulse must be 450mS min)
_delay_cycles(2); //250nS

//Enable the selected controller's read data onto the port
PORTC|=PORTC7_LCD_E;
//The data is not valid for 320nS
_delay_cycles(4);
//Wait for the busy bit to drop
while(PINA&0x80);
//Terminate the read
PORTC&=~PORTC7_LCD_E;

//Tell the LCD that we are writing to it.
//(Must happen 140nS before the RISING edge of E.)
PORTC&=~PORTC6_LCD_RW; //125nS
//Talk to both controllers
//(Must happen 140nS before the RISING edge of E.)
PORTC&=~PORTC0_LCD_CS1; //125nS
//stretch LOW E pulse width above the minimum of 450nS
_delay_cycles(2); //250nS
//Strobe the E pin. We are still aimed at the status/instruction register.
PORTC|=PORTC7_LCD_E;
//Write the data to the output latches of port A
//(Must happen 200nS before the FALLING edge of E.)
PORTA=data; //62.5nS
//Go back to port A as an output
DDRA=0xFF; //125nS
//stretch HIGH E pulse width above the minimum of 450nS
_delay_cycles(3); //312.5nS
PORTC&=~PORTC7_LCD_E;
}
//=====
// PORTC0_LCD_CS1 and PORTD6_LCD_CS2 must be set to select the desired
// controller
//-----
void write_lcd_data(ubyte data)
{
//We need to wait until the busy bit is clear.
//Talk to the status (instruction) register.
//(Must happen 140nS before the RISING edge of E.)
PORTC&=~PORTC1_LCD_DI;
//Tell the LCD we are going to be reading it
//(Must happen 140nS before the RISING edge of E.)
PORTC|=PORTC6_LCD_RW;
//Make port A high-impedance
```



```
DDRA=0x00;
//Enable the selected controller's read data onto the port
PORTC|=PORTC7_LCD_E;
//The data from the LCD is not valid for 320nS
_delay_cycles(4); //375nS
//Wait for the busy bit to drop
while(PINA&0x80);
//Terminate the read
PORTC&=~PORTC7_LCD_E;
//Tell the LCD that we are writing to it.
//(Must happen 140nS before the RISING edge of E.)
PORTC&=~PORTC6_LCD_RW; //125nS
//Aim at the data register.
//(Must happen 140nS before the RISING edge of E.)
PORTC|=PORTC1_LCD_DI; //125nS
//stretch LOW E pulse width above the minimum of 450nS
_delay_cycles(2); //250nS
//Strobe the E pin.
PORTC|=PORTC7_LCD_E;
//Write the data to the output latches of port A
//(Must happen 200nS before the FALLING edge of E.)
PORTA=data; //62.5nS
//Go back to port A as an output
DDRA=0xFF; //125nS
//stretch HIGH E pulse width above the minimum of 450nS
_delay_cycles(3); //312.5nS
//Terminate the write
PORTC&=~PORTC7_LCD_E;
}
//=====
// Takes about 5.08ms (201.7KB/S) reading busy flag
void UpdateLCD(void)
{
register ubyte
 *left_data;
register ubyte
 *right_data;
register ubyte
 page_address;
register ubyte
 column_address;

//Initialize our source data pointers.
left_data=&display[0][0];
right_data=&display[0][64];

//Make sure we are not in a write cycle
PORTC&=~PORTC7_LCD_E;

//Make sure the LCD thinks we are writing
PORTC&=~PORTC6_LCD_RW;

for(page_address=0;page_address<=7;page_address++)
{
```



```
//Set Y address (page, or horizontal stripe of 8 pixels) (controller docs call this
"X")
write_both_lcd_control_registers(0xB8|page_address);
//Set X address 0 (right to left) (controller docs call this "Y")
write_both_lcd_control_registers(0x40);

for(column_address=0;column_address<=63;column_address++)
{
//Talk to the left controller only
PORTC&=~PORTC0_LCD_CS1;
PORTD|=PORTD6_LCD_CS2;
write_lcd_data(*left_data++);
//Talk to the right controller only
PORTC|=PORTC0_LCD_CS1;
PORTD&=~PORTD6_LCD_CS2;
write_lcd_data(*right_data++);
}
//Skip down to the next line
left_data+=64;
right_data+=64;
}
}
//=====
void InitializeLCD(void)
{
//Display on
write_both_lcd_control_registers(0x3F);

//Set Start Line 0
write_both_lcd_control_registers(0xC0);

//Clear the display memeory
memset(display,0x00,sizeof(display));
}
//=====
```



APPENDIX C: SAMSUNG S6B0107 64 CH COMMON DRIVER

The complete Samsung's *S6B0107 64 CH Common Driver for Dot Matrix LCD* specifications follows.

S6B0107

64CH COMMON DRIVER FOR DOT MATRIX LCD

July 2001

Ver. 0.0

Contents in this document are subject to change without notice. No part of this document may be reproduced or transmitted in any form or by any means, electronic or mechanical, for any purpose, without the express written permission of LCD Driver IC Team.

Precautions for Light

Light has characteristics to move electrons in the integrated circuitry of semiconductors, therefore may change the characteristics of semiconductor devices when irradiated with light. Consequently, the users of the packages which may expose chips to external light such as COB, COG, TCP and COF must consider effective methods to block out light from reaching the IC on all parts of the surface area, the top, bottom and the sides of the chip. Follow the precautions below when using the products.

1. Consider and verify the protection of penetrating light to the IC at substrate (board or glass) or product design stage.
2. Always test and inspect products under the environment with no penetration of light.

S6B0107 Specification Revision History		
Version	Content	Date
0.0	Original	July.2001

CONTENTS

INTRODUCTION	1
BLOCK DIAGRAM	2
PIN CONFIGURATION	3
100-QFP	3
PAD DIAGRAM (CHIP LAYOUT FOR THE 100QFP).....	4
PAD CENTER COORDINATES (100QFP).....	5
100-TQFP (S6B2107).....	6
PAD DIAGRAM (CHIP LAYOUT FOR THE 100-TQFP).....	7
PAD CENTER COORDINATES (100-TQFP).....	8
PIN DESCRIPTION	10
ELECTRICAL CHARACTERISTICS	13
DC CHARACTERISTICS	13
AC CHARACTERISTICS ($V_{DD} = 5V \pm 10\%$, $T_A = -30^{\circ}C$ to $+85^{\circ}C$).....	14
FUNCTIONAL DESCRIPTION	17
TIMING DIAGRAM	19
1/48 DUTY TIMING (MASTER MODE).....	19
1/128 DUTY TIMING (MASTER MODE).....	20
1/48 DUTY TIMING (SLAVE MODE).....	21
POWER DRIVER CIRCUIT.....	22
APPLICATION CIRCUIT	23

INTRODUCTION

The S6B0107 (TQFP type: S6B2107) is a LCD driver LSI with 64 channel outputs for dot matrix liquid crystal graphic display systems. This device provides 64 shift registers and 64 output drivers. It generates the timing signal to control the S6B0108 (64 channel segment driver - TQFP type: S6B2108). The S6B0107 is fabricated by low power CMOS high voltage process technology, and is composed of the liquid crystal display system in combination with the S6B0108 (64 channel segment driver).

FEATURES

- Dot matrix LCD common driver with 64 channel output
- 64-bit shift register at internal LCD driver circuit
- Internal timing generator circuit for dynamic display
- Selection of master/slave mode
- Applicable LCD duty: 1/48, 1/64, 1/96, 1/128
- Power supply voltage: + 5V \pm 10%
- LCD driving voltage: 8V - 17V ($V_{DD}-V_{EE}$)
- Interface

Driver		Controller
COMMON	SEGMENT	
Other S6B0107	S6B0108	MPU

- High voltage CMOS process
- 100QFP/100TQFP and bare chip available

BLOCK DIAGRAM

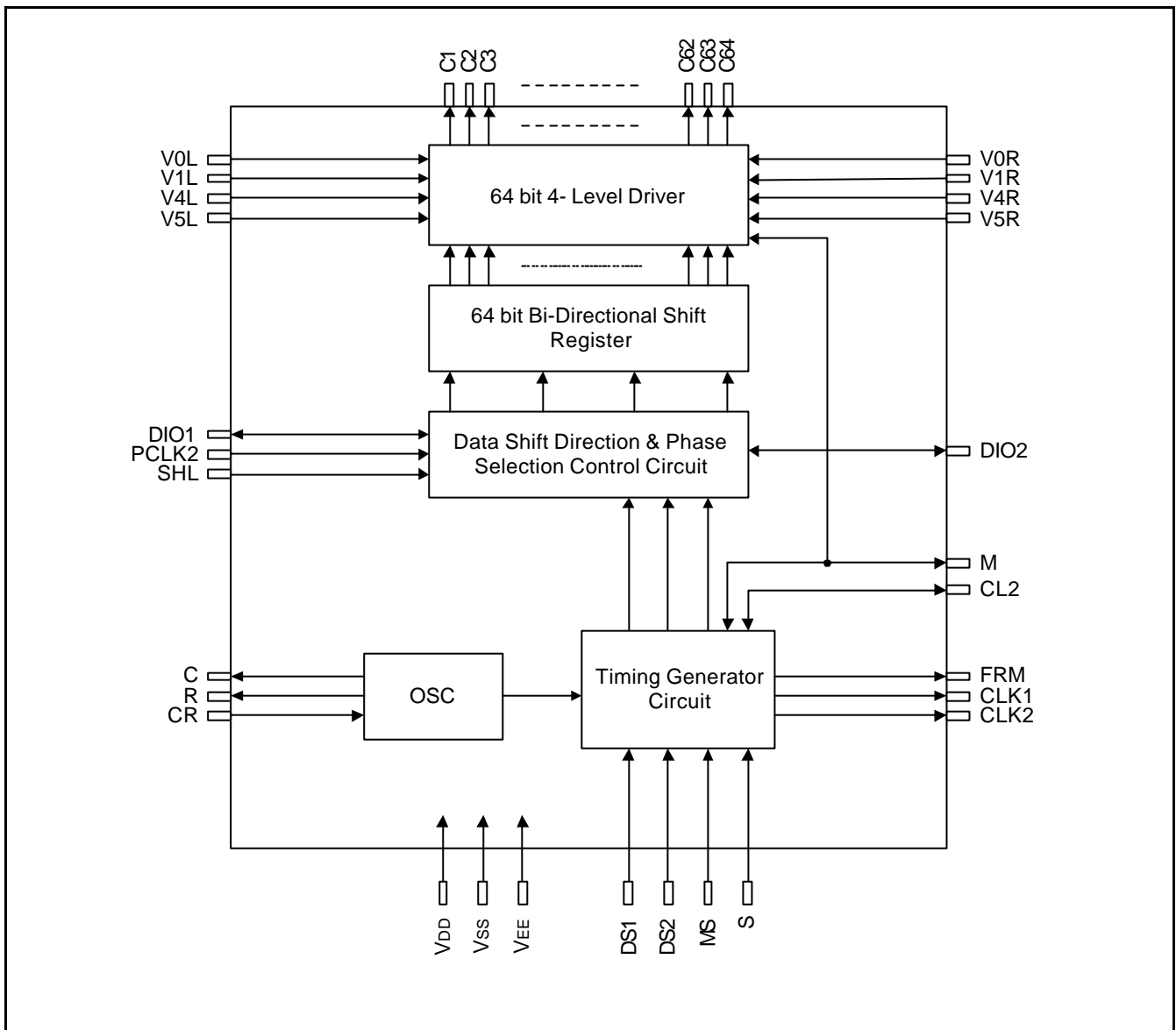

PIN CONFIGURATION

100-QFP

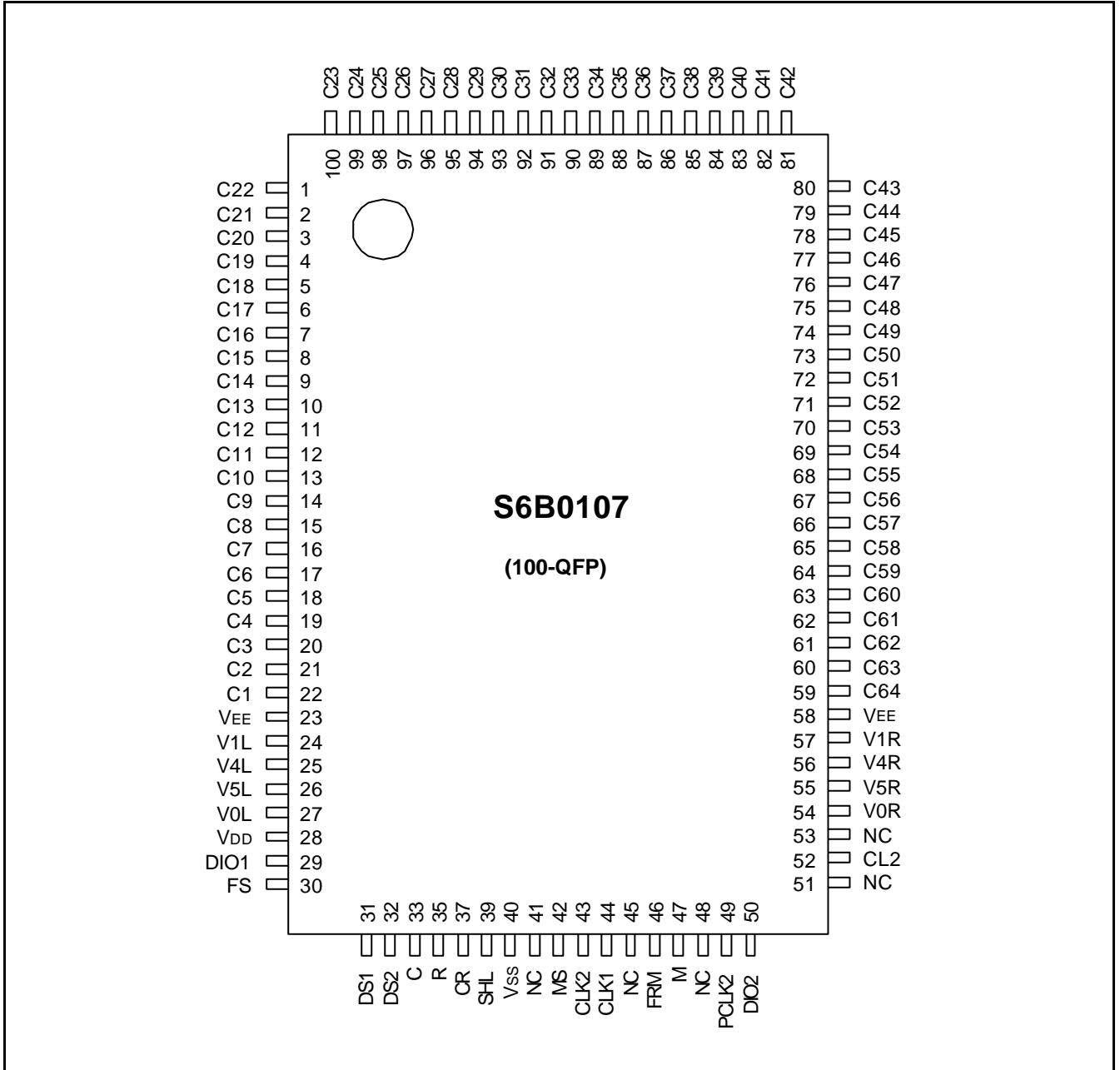

PAD DIAGRAM (CHIP LAYOUT FOR THE 100QFP)

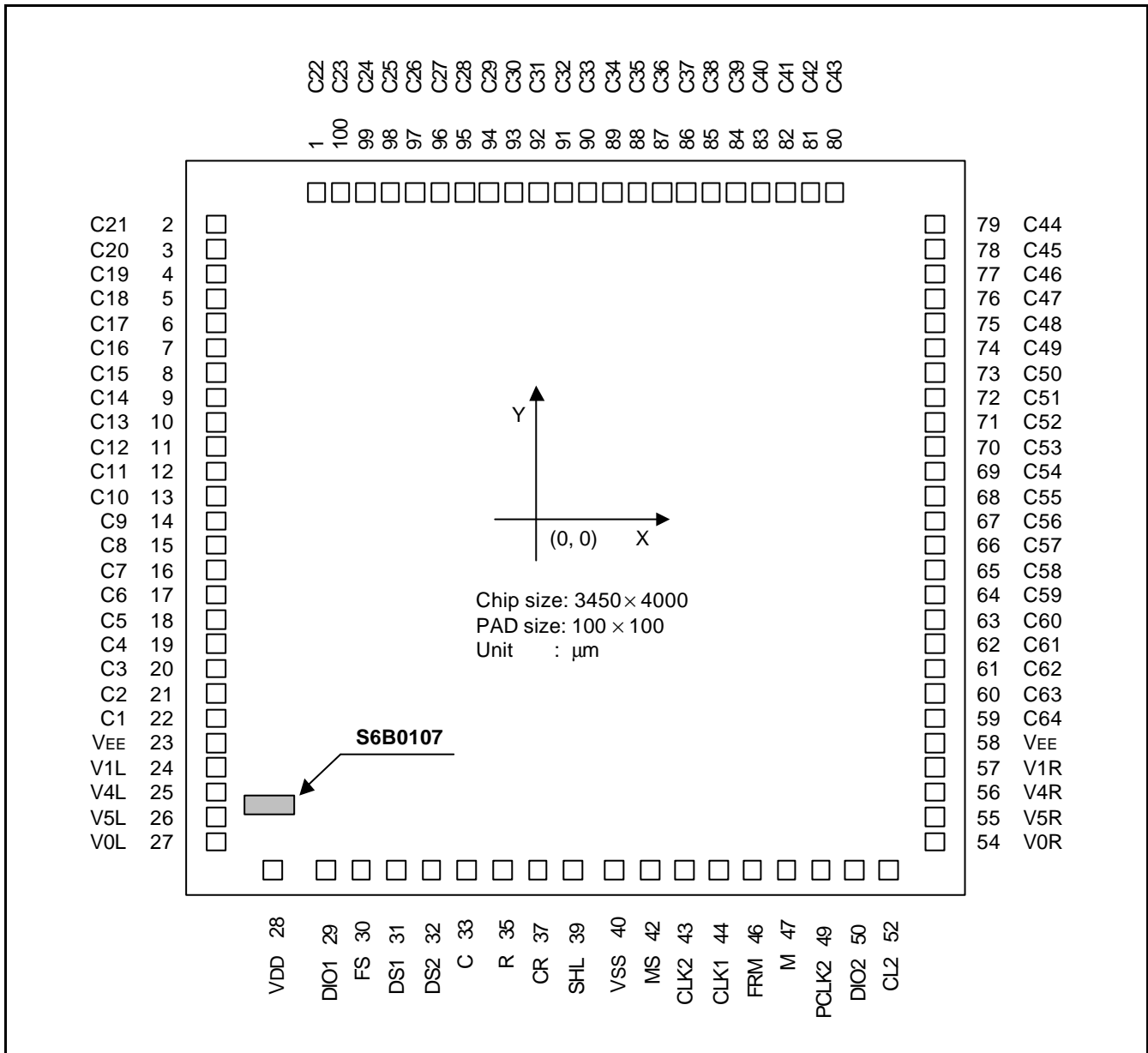

There is the mark S6B0107 on the center of the chip.

PAD CENTER COORDINATES (100QFP)

Pad Number	Pad Name	Coordinate		Pad Number	Pad Name	Coordinate		Pad Number	Pad Name	Coordinate	
		X	Y			X	Y			X	Y
1	C22	-1314.5	1775.4	32	DS2	-677.6	-1775	71	C52	1500.9	630
2	C21	-1499.9	1630	33	C	-527.6	-1775	72	C51	1500.9	755
3	C20	-1499.9	1505	35	R	-377.6	-1775	73	C50	1500.9	880
4	C19	-1499.9	1380	37	CR	-227.6	-1775	74	C49	1500.9	1005
5	C18	-1499.9	1255	39	SHL	-77.6	-1775	75	C48	1500.9	1130
6	C17	-1499.9	1130	40	V _{SS}	113.8	-1775	76	C47	1500.9	1255
7	C16	-1499.9	1005	42	MS	308.7	-1775	77	C46	1500.9	1380
8	C15	-1499.9	880	43	CLK2	458.7	-1775	78	C45	1500.9	1505
9	C14	-1499.9	755	44	CLK1	608.7	-1775	79	C44	1500.9	1630
10	C13	-1499.9	630	46	FRM	758.7	-1775	80	C43	1310.5	1775.4
11	C12	-1499.9	505	47	M	908.7	-1775	81	C42	1185.5	1775.4
12	C11	-1499.9	380	49	PCLK2	1058.7	-1775	82	C41	1060.5	1775.4
13	C10	-1499.9	255	50	DI02	1208.7	-1775	83	C40	935.5	1775.4
14	C9	-1499.9	130	52	CL2	1358.7	-1775	84	C39	810.5	1775.4
15	C8	-1499.9	5	54	V0R	1500.9	-1495	85	C38	685.5	1775.4
16	C7	-1499.9	-120	55	V5R	1500.9	-1370	86	C37	560.5	1775.4
17	C6	-1499.9	-245	56	V4R	1500.9	-1245	87	C36	435.5	1775.4
18	C5	-1499.9	-370	57	V1R	1500.9	-1120	88	C35	310.5	1775.4
19	C4	-1499.9	-495	58	V _{EE}	1500.9	-995	89	C34	185.5	1775.4
20	C3	-1499.9	-620	59	C64	1500.9	-870	90	C33	60.5	1775.4
21	C2	-1499.9	-745	60	C63	1500.9	-745	91	C32	-64.5	1775.4
22	C1	-1499.9	-870	61	C62	1500.9	-620	92	C31	-189.5	1775.4
23	V _{EE}	-1499.9	-995	62	C61	1500.9	-495	93	C30	-314.5	1775.4
24	V1L	-1499.9	-1120	63	C60	1500.9	-370	94	C29	-439.5	1775.4
25	V4L	-1499.9	-1245	64	C59	1500.9	-245	95	C28	-564.5	1775.4
26	V5L	-1499.9	-1370	65	C58	1500.9	-120	96	C27	-689.5	1775.4
27	V0L	-1499.9	-1495	66	C57	1500.9	5	97	C26	-814.5	1775.4
28	V _{DD}	-1345.6	-1775	67	C56	1500.9	130	98	C25	-939.5	1775.4
29	DI01	-1127.6	-1775	68	C55	1500.9	255	99	C24	-1064.5	1775.4
30	FS	-977.6	-1775	69	C54	1500.9	380	100	C23	-1189.5	1775.4
31	DS1	-827.6	-1775	70	C53	1500.9	505				

100-TQFP (S6B2107)

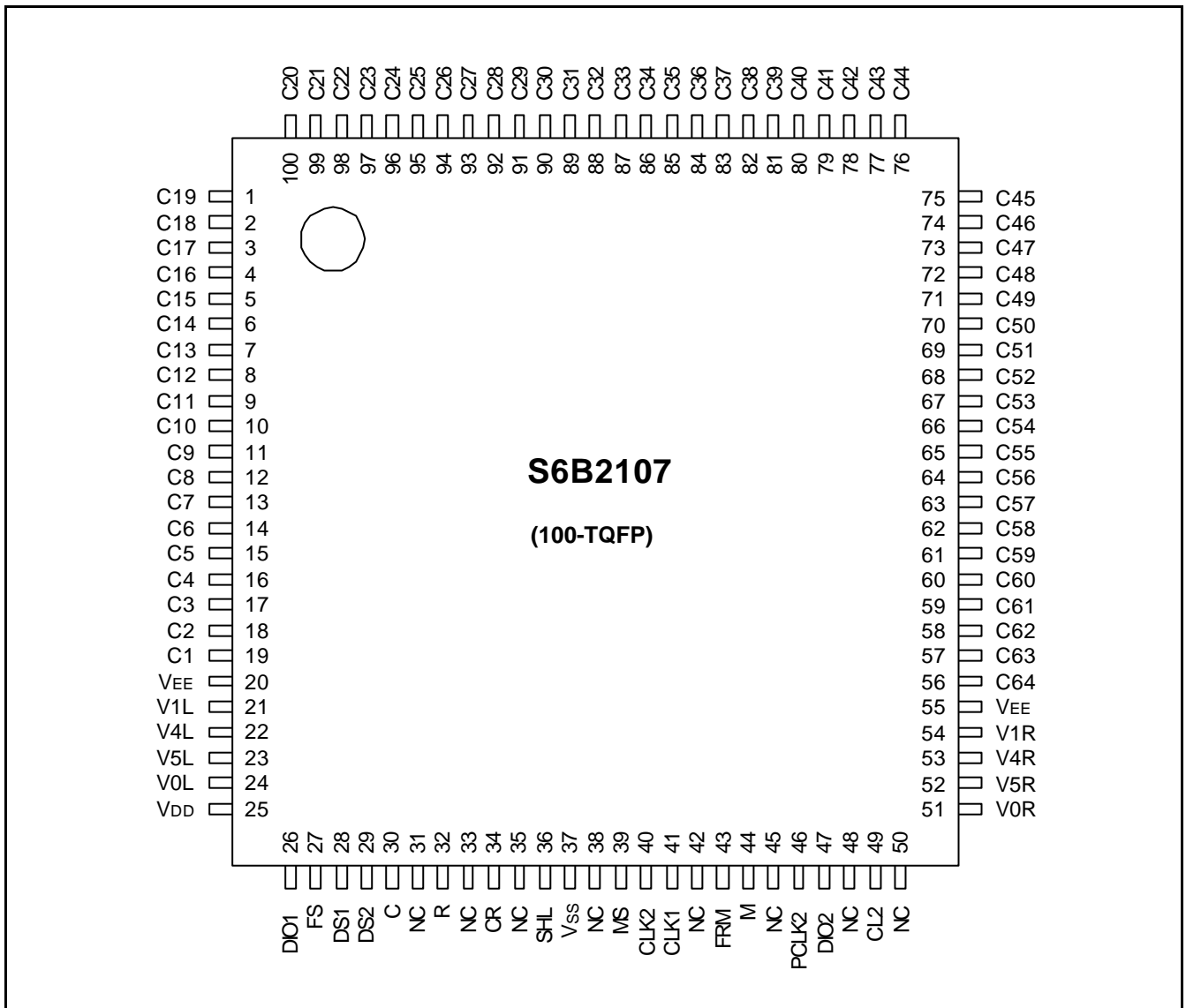

PAD DIAGRAM (CHIP LAYOUT FOR THE 100-TQFP)

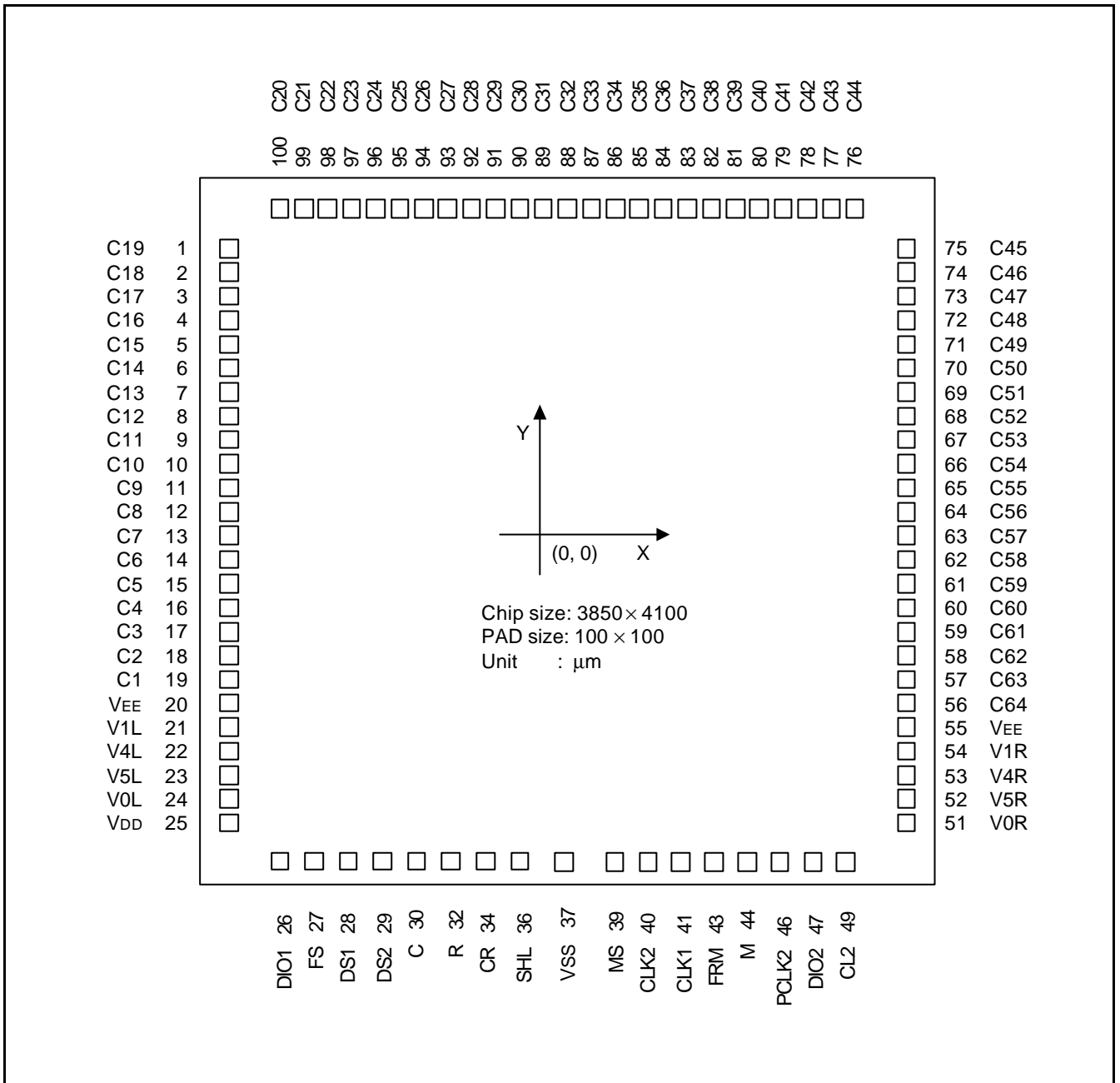

NOTE: There is the mark S6B2107 on the center of the chip.

PAD CENTER COORDINATES (100-TQFP)

Pad Number	Pad Name	Coordinate		Pad Number	Pad Name	Coordinate		Pad Number	Pad Name	Coordinate	
		X	Y			X	Y			X	Y
1	C19	-1697	1534	35	NC			69	C51	1697	784
2	C18	-1697	1409	36	SHL	-195	-1821	70	C50	1697	909
3	C17	-1697	1284	37	V _{SS}	0	-1821	71	C49	1697	1034
4	C16	-1697	1159	38	NC			72	C48	1697	1159
5	C15	-1697	1034	39	MS	195	-1821	73	C47	1697	1284
6	C14	-1697	909	40	CLK2	345	-1821	74	C46	1697	1409
7	C13	-1697	784	41	CLK1	495	-1821	75	C45	1697	1534
8	C12	-1697	659	42	NC			76	C44	1500	1822
9	C11	-1697	534	43	FRM	645	-1821	77	C43	1375	1822
10	C10	-1697	409	44	M	795	-1821	78	C42	1250	1822
11	C9	-1697	284	45	NC			79	C41	1125	1822
12	C8	-1697	159	46	PCLK2	945	-1821	80	C40	1000	1822
13	C7	-1697	34	47	DIO2	1095	-1821	81	C39	875	1822
14	C6	-1697	-91	48	NC			82	C38	750	1822
15	C5	-1697	-216	49	CL2	1245	-1821	83	C37	625	1822
16	C4	-1697	-341	50	NC			84	C36	500	1822
17	C3	-1697	-466	51	V0R	1697	-1466	85	C35	375	1822
18	C2	-1697	-591	52	V5R	1697	-1341	86	C34	250	1822
19	C1	-1697	-716	53	V4R	1697	-1216	87	C33	125	1822
20	V _{EE}	-1697	-841	54	V1R	1697	-1091	88	C32	0	1822
21	V1L	-1697	-966	55	V _{EE}	1697	-966	89	C31	-125	1822
22	V4L	-1697	-1091	56	C64	1697	-841	90	C30	-250	1822
23	V5L	-1697	-1216	57	C63	1697	-716	91	C29	-375	1822
24	V0L	-1697	-1341	58	C62	1697	-591	92	C28	-500	1822
25	V _{DD}	-1697	-1466	59	C61	1697	466	93	C27	-625	1822
26	DIO1	-1245	-1821	60	C60	1697	-341	94	C26	-750	1822
27	FS	-1095	-1821	61	C59	1697	-216	95	C25	-875	1822
28	DS1	-945	-1821	62	C58	1697	-91	96	C24	-1000	1822
29	DS2	-795	-1821	63	C57	1697	34	97	C23	-1125	1822

30	C	-645	-1821	64	C56	1697	159	98	C22	-1250	1822
31	NC			65	C55	1697	284	99	C21	-1375	1822
32	R	-495	-1821	66	C54	1697	409	100	C20	-1500	1822
33	NC			67	C53	1697	534				
34	CR	-345	-1821	68	C52	1697	659				

PIN DESCRIPTION

Table 1. Pin Description

Pin Number QFP (TQFP)	Symbol	I/O	Description						
28(25) 40(37) 23(20), 58(55)	V_{DD} V_{SS} V_{EE}	Power	For internal logic circuit (+5V ± 10%) GND (= 0 V) For LCD driver circuit						
27(24), 54(51) 24(21), 57(54) 25(22), 56(53) 26(23), 55(52)	V_{0L} , V_{0R} V_{1L} , V_{1R} V_{4L} , V_{4R} V_{5L} , V_{5R}	Power	Bias supply voltage terminals to drive LCD. <table border="1" style="margin-left: 20px;"> <thead> <tr> <th>Select Level</th> <th>Non-Select Level</th> </tr> </thead> <tbody> <tr> <td>V_{0L} (R), V_{5L} (R)</td> <td>V_{1L} (R), V_{4L} (R)</td> </tr> </tbody> </table> <p>V_{0L} and V_{0R} (V_{1L} & V_{1R}, V_{4L} & V_{4R}, V_{5L} & V_{5R}) should be connected by the same voltage.</p>	Select Level	Non-Select Level	V_{0L} (R), V_{5L} (R)	V_{1L} (R), V_{4L} (R)		
Select Level	Non-Select Level								
V_{0L} (R), V_{5L} (R)	V_{1L} (R), V_{4L} (R)								
42(39)	MS	Input	Selection of master/slave mode - Master mode (MS = 1) DIO1, DIO2, CL2 and M is output state. - Slave mode (MS = 0) SHL = 1 → DIO1 is input state (DIO2 is output state) SHL = 0 → DIO2 is input state (DIO1 is output state) CL2 and M are input state.						
39(36)	SHL	Input	Selection of data shift direction. <table border="1" style="margin-left: 20px;"> <thead> <tr> <th>SHL</th> <th>Data Shift Direction</th> </tr> </thead> <tbody> <tr> <td>H</td> <td>DIO1 → C1 C64 → DIO0</td> </tr> <tr> <td>L</td> <td>DIO2 → C64 C1 → DIO0</td> </tr> </tbody> </table>	SHL	Data Shift Direction	H	DIO1 → C1 C64 → DIO0	L	DIO2 → C64 C1 → DIO0
SHL	Data Shift Direction								
H	DIO1 → C1 C64 → DIO0								
L	DIO2 → C64 C1 → DIO0								
49(46)	PCLK2	Input	Selection of shift clock (CL2) phase. <table border="1" style="margin-left: 20px;"> <thead> <tr> <th>PCLK2</th> <th>Shift Clock (CL2) Phase</th> </tr> </thead> <tbody> <tr> <td>H</td> <td>Data shift at the rising edge of CL2</td> </tr> <tr> <td>L</td> <td>Data shift at the falling edge of CL2</td> </tr> </tbody> </table>	PCLK2	Shift Clock (CL2) Phase	H	Data shift at the rising edge of CL2	L	Data shift at the falling edge of CL2
PCLK2	Shift Clock (CL2) Phase								
H	Data shift at the rising edge of CL2								
L	Data shift at the falling edge of CL2								
30(27)	FS	Input	Selection of oscillation frequency. - Master mode When the frame frequency is 70 Hz, the oscillation frequency should be $f_{osc} = 430\text{kHz}$ at FS = 1(V_{DD}) $f_{osc} = 215\text{kHz}$ at FS = 0(V_{SS}) - Slave mode Connect to V_{DD} .						

Table 1. Pin Description (Continued)

Pin Number QFP (TQFP)	Symbol	I/O	Description																		
31(28) 32(29)	DS1 DS2	Input	<p>Selection of display duty.</p> <ul style="list-style-type: none"> - Master mode <table border="1"> <thead> <tr> <th>DS1</th> <th>DS2</th> <th>Duty</th> </tr> </thead> <tbody> <tr> <td>L</td> <td>L</td> <td>1/48</td> </tr> <tr> <td>L</td> <td>H</td> <td>1/64</td> </tr> <tr> <td>H</td> <td>L</td> <td>1/96</td> </tr> <tr> <td>H</td> <td>H</td> <td>1/128</td> </tr> </tbody> </table> <ul style="list-style-type: none"> - Slave mode Connect to V_{DD} 	DS1	DS2	Duty	L	L	1/48	L	H	1/64	H	L	1/96	H	H	1/128			
DS1	DS2	Duty																			
L	L	1/48																			
L	H	1/64																			
H	L	1/96																			
H	H	1/128																			
33(30) 35(32) 37(34)	C R CR		<p>RC Oscillator</p> <ul style="list-style-type: none"> - Master mode: Use these terminals as shown below. <ul style="list-style-type: none"> - Slave mode: Stop the oscillator as shown below. 																		
44(41) 43(40)	CLK1 CLK2	Output	<p>Operating clock output for the S6B0108</p> <ul style="list-style-type: none"> - Master mode: connection to CLK1 and CLK2 of the S6B0108 - Slave mode: open 																		
46(43)	FRM	Output	<p>Synchronous frame signal.</p> <ul style="list-style-type: none"> - Master mode: connection to FRM of the S6B0108 - Slave mode: open 																		
47(44)	M	Input/ Output	<p>Alternating signal input for LCD driving.</p> <ul style="list-style-type: none"> - Master mode: output state Connection to M of the S6B0108 - Slave mode: input state Connection to the controller 																		
52(49)	CL2	Input / Output	<p>Data shift clock</p> <ul style="list-style-type: none"> - Master mode: output state Connection to CL of the S6B0108 - Slave mode: input state Connection to shift clock terminal of the controller. 																		
29(26) 50(47)	DIO1 DIO2	Input/ Output	<p>Data input/output pin of internal shift register.</p> <table border="1"> <thead> <tr> <th>MS</th> <th>DS2</th> <th>DIO1</th> <th>DIO2</th> </tr> </thead> <tbody> <tr> <td rowspan="2">H</td> <td>H</td> <td>Output</td> <td>Output</td> </tr> <tr> <td>L</td> <td>Output</td> <td>Output</td> </tr> <tr> <td rowspan="2">L</td> <td>H</td> <td>Input</td> <td>Output</td> </tr> <tr> <td>L</td> <td>Output</td> <td>Input</td> </tr> </tbody> </table>	MS	DS2	DIO1	DIO2	H	H	Output	Output	L	Output	Output	L	H	Input	Output	L	Output	Input
MS	DS2	DIO1	DIO2																		
H	H	Output	Output																		
	L	Output	Output																		
L	H	Input	Output																		
	L	Output	Input																		

Table 1. Pin Description (Continued)

Pin Number QFP (TQFP)	Symbol	I/O	Description															
22-1(19-1) 100-59(100-56)	C1-C64	Output	Common signal output for LCD driving. <table border="1" style="margin-left: 20px;"> <thead> <tr> <th>Data</th> <th>M</th> <th>Out</th> </tr> </thead> <tbody> <tr> <td>L</td> <td>L</td> <td>V₁</td> </tr> <tr> <td>L</td> <td>H</td> <td>V₄</td> </tr> <tr> <td>H</td> <td>L</td> <td>V₅</td> </tr> <tr> <td>H</td> <td>H</td> <td>V₀</td> </tr> </tbody> </table>	Data	M	Out	L	L	V ₁	L	H	V ₄	H	L	V ₅	H	H	V ₀
Data	M	Out																
L	L	V ₁																
L	H	V ₄																
H	L	V ₅																
H	H	V ₀																
34(31), 36(33) 38(35), 41(38) 45(42), 48(45) 51(48), 53(50)	NC		No connection															

MAXIMUM ABSOLUTE LIMIT

Characteristic	Symbol	Value	Unit	Note
Operating voltage	V _{DD}	-0.3 - +7.0	V	(1)
Supply voltage	V _{EE}	V _{DD} -19.0 - V _{DD} +0.3	V	(4)
Driver supply voltage	V _B	-0.3 - V _{DD} +0.3	V	(1), (2)
	V _{LCD}	V _{EE} -0.3 - V _{DD} +0.3	V	(3), (4)
Operating temperature	T _{OPR}	-30 - +85	°C	-
Storage temperature	T _{STG}	-55 - +125	°C	-

NOTES:

1. Based on V_{SS} = 0V
2. Applies to input terminals and I/O terminals at high impedance. (Except V0L(R), V1L(R), V4L(R) and V5L(R)).
3. Applies to V0L(R), V1L(R), V4L(R) and V5L(R).
4. Voltage level: V_{DD} ≥ V0L = V0R ≥ V1L = V1R ≥ V4L = V4R ≥ V5L = V5R ≥ V_{EE}.

ELECTRICAL CHARACTERISTICS

DC CHARACTERISTICS

($V_{DD} = +5V \pm 10\%$, $V_{SS} = 0V$, $|V_{DD}-V_{EE}|=8 - 17V$, $T_a = -30$ to $+85^\circ C$)

Characteristic		Symbol	Condition	Min	Typ	Max	Unit	Note
Input Voltage	High	V_{IH}	-	$0.7V_{DD}$	-	V_{DD}	V	(1)
	Low	V_{IL}		V_{SS}	-	$0.3V_{DD}$		
Output Voltage	High	V_{OH}	$I_{OH} = -0.4mA$	$V_{DD}-0.4$	-	-	V	(2)
	Low	V_{OL}	$I_{OL} = 0.4mA$	-	-	0.4		
Input leakage current		I_{LKG}	$V_{IN} = V_{DD}-V_{SS}$	-1.0	-	1.0	μA	(1)
OSC frequency		f_{OSC}	$R_f = 47k\Omega \pm 2\%$ $C_f = 20pf \pm 5\%$	315	450	585	kHz	
On resistance (VDIV-Cl)		R_{ON}	$V_{DD}-V_{EE} = 17V$ Load current = $\pm 150\mu A$	-	-	1.5	K Ω	
Operating current		I_{DD1}	Master mode 1/128 Duty	-	-	1.0	mA	(3)
		I_{DD2}	Slave mode 1/128 Duty	-	-	200	μA	(4)
Supply current		I_{EE}	Master mode 1/128 Duty	-	-	100		(5)
Operating Frequency		f_{op1}	Master mode External clock	50	-	600	kHz	
Frequency		f_{op2}	Slave mode	0.5	-	1500		

NOTES:

1. Applies to input terminals FS, DS1, DS2, CR, SHL, MS and PCLK2 and I/O terminals DIO1, DIO2, M and CL2 in the input state.
2. Applies to output terminals CLK1, CLK2 and FRM and I/O terminals DIO1, DIO2, M and CL2 in the output state.
3. This value is specified at about the current flowing through V_{SS} . Internal oscillation circuit: $R_f = 47k\Omega$, $C_f = 20pF$ Each terminal of DS1, DS2, FS, SHL and MS is connected to V_{DD} and out is no load.
4. This value is specified at about the current flowing through V_{SS} . Each terminal of DS1, DS2, FS, SHL, PCLK2 and CR is connected to V_{DD} , and MS is connected to V_{SS} . CL2, M, DIO1 is external clock.
5. This value is specified at about the current flowing through V_{EE} . Don't connect to V_{LCD} (V1-V5).

AC CHARACTERISTICS ($V_{DD} = 5V \pm 10\%$, $T_A = -30^{\circ}C$ to $+85^{\circ}C$)

Master Mode

($MS = V_{DD}$, $PCLK2 = V_{DD}$, $C_f = 20pF$, $R_f = 47k\Omega$)

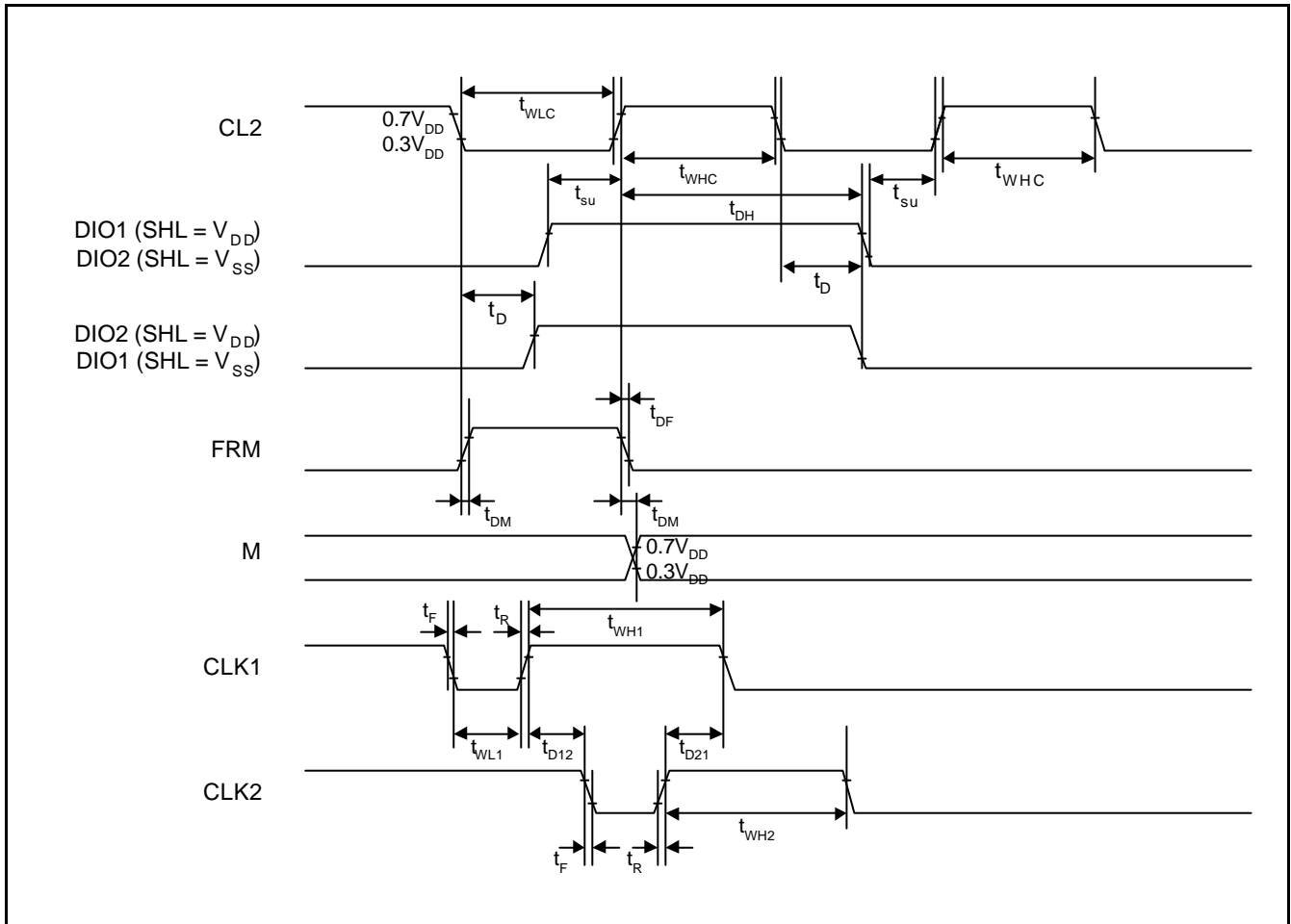

Master Mode

Characteristic	Symbol	Min	Typ	Max	Unit
Data setup time	t_{SU}	20	–	–	μs
Data hold time	t_{DH}	40	–	–	
Data delay time	t_D	5	–	–	
FRM delay time	t_{DF}	-2	–	2	
M delay time	t_{DM}	-2	–	2	
CL2 low level width	t_{WLC}	35	–	–	
CL2 high level width	t_{WHC}	35	–	–	ns
CLK1 low level width	t_{WL1}	700	–	–	
CLK2 low level width	t_{WL2}	700	–	–	
CLK1 high level width	t_{WH1}	2100	–	–	
CLK2 high level width	t_{WH2}	2100	–	–	
CLK1-CLK2 phase difference	t_{D12}	700	–	–	
CLK2-CLK1 phase difference	t_{D21}	700	–	–	
CLK1, CLK2 rise/fall time	t_R/t_F	–	–	150	

Slave Mode (MS = V_{SS})

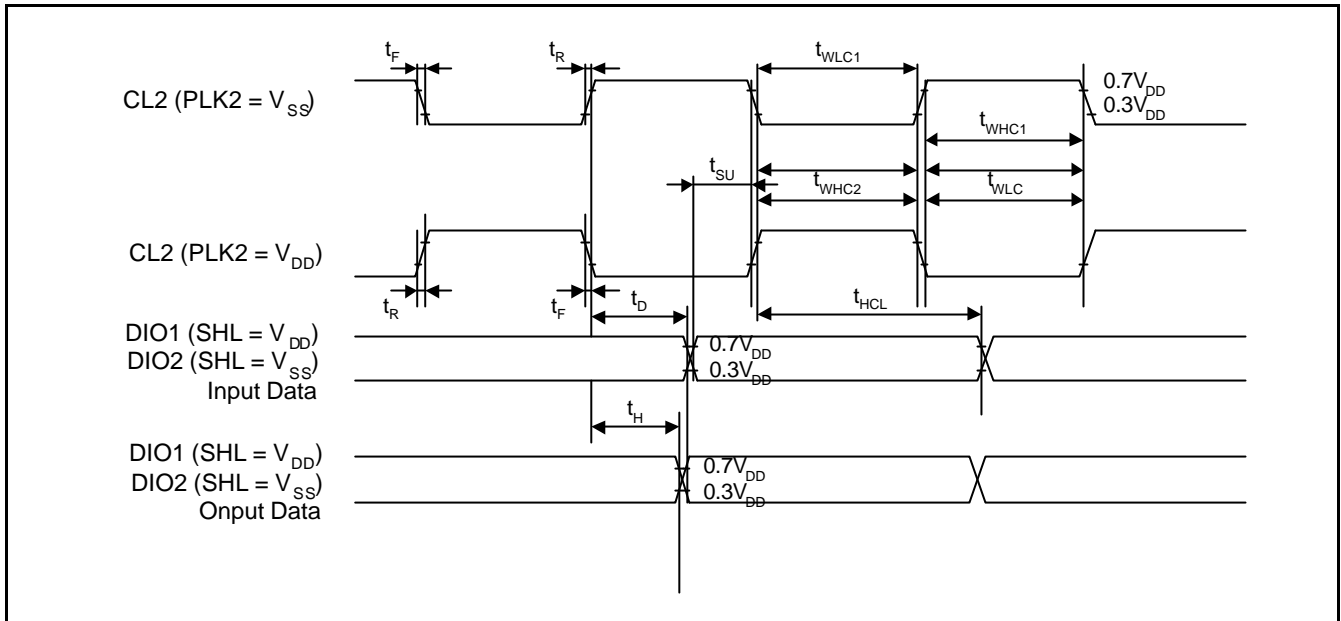

Characteristics	Symbol	Min	Typ	Max	Unit	Note
CL2 low level width	t _{WLC1}	450	–	–	ns	PCLK2 = V _{SS}
CL2 high level width	t _{WHC1}	150	–	–	ns	PCLK2 = V _{SS}
CL2 low level width	t _{WLC2}	150	–	–	ns	PCLK2 = V _{DD}
CL2 high level width	t _{WHL}	450	–	–	ns	PCLK2 = V _{DD}
Data setup time	t _{SU}	100	–	–	ns	
Data hold time	t _{DH}	100	–	–	ns	
Data delay time	t _D	–	–	200	ns	(NOTE)
Output data hold time	t _H	10	–	–	ns	
CL2 rise/fall time	t _R /t _F	–	–	30	ns	

NOTE: Connect load CL = 30pF

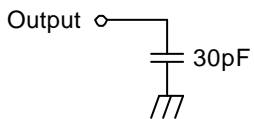

FUNCTIONAL DESCRIPTION

RC Oscillator

The RC Oscillator generates CL2, M, FRM of the S6B0107, and CLK1 and CLK2 of the S6B0108 by the oscillation resistor R and capacitor C.

When selecting the master/slave mode, the oscillation circuit is as following:

Master Mode: In the master mode, use these terminals as shown below.



Slave Mode: In the slave mode, stop the oscillator as shown below.

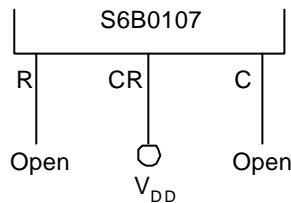

Timing Generation Circuit

It generates CL2, M, FRM, CLK1 and CLK2 by the frequency from the oscillation circuit.

Selection of Master/Slave (M/S) Mode

- When M/S is "H", it generates CL2, M, FRM, CLK1 and CLK2 internally.
- When M/S is "L", it operates by receiving M and CL2 from the mater device

Frequency Selection (FS)

To adjust FRM frequency by 70Hz, the oscillation frequency should be as follows:

FS	Oscillation Frequency
H	$f_{OSC} = 430kHz$
L	$f_{OSC} = 215kHz$

In the slave mode, it is connected to V_{DD} .

Duty Selection (DS1, DS2)

It provides various duty selections according to DS1 and DS2.

DS1	DS2	DUTY
L	L	1/48
	H	1/64
H	L	1/96
	H	1/128

Data Shift & Phase Select Control

Phase Selection

It is a circuit to shift data on synchronization or rising edge, or falling edge of the CL2 according to PCLK2.

PCLK2	Phase Selection
H	Data shift on rising edge of CL2
L	Data shift on falling edge of CL2

Data Shift Direction Selection

When M/S is connected to V_{DD} , DIO1 and DIO2 terminal is only output.

When M/S is connected to V_{SS} , it depends on the SHL.

MS	SHL	DIO1	DIO2	Direction of Data
H	H	Output	Output	C1 → C64
	L	Output	Output	C64 → C1
L	H	Input	Output	DIO1 → C1 → C64 → DIO2
	L	Output	Input	DIO2 → C64 → C1 → DIO1

TIMING DIAGRAM

1/48 DUTY TIMING (MASTER MODE)

Condition: DS1 = L, DS2 = L, SHL = H(L), PCLK2 = H

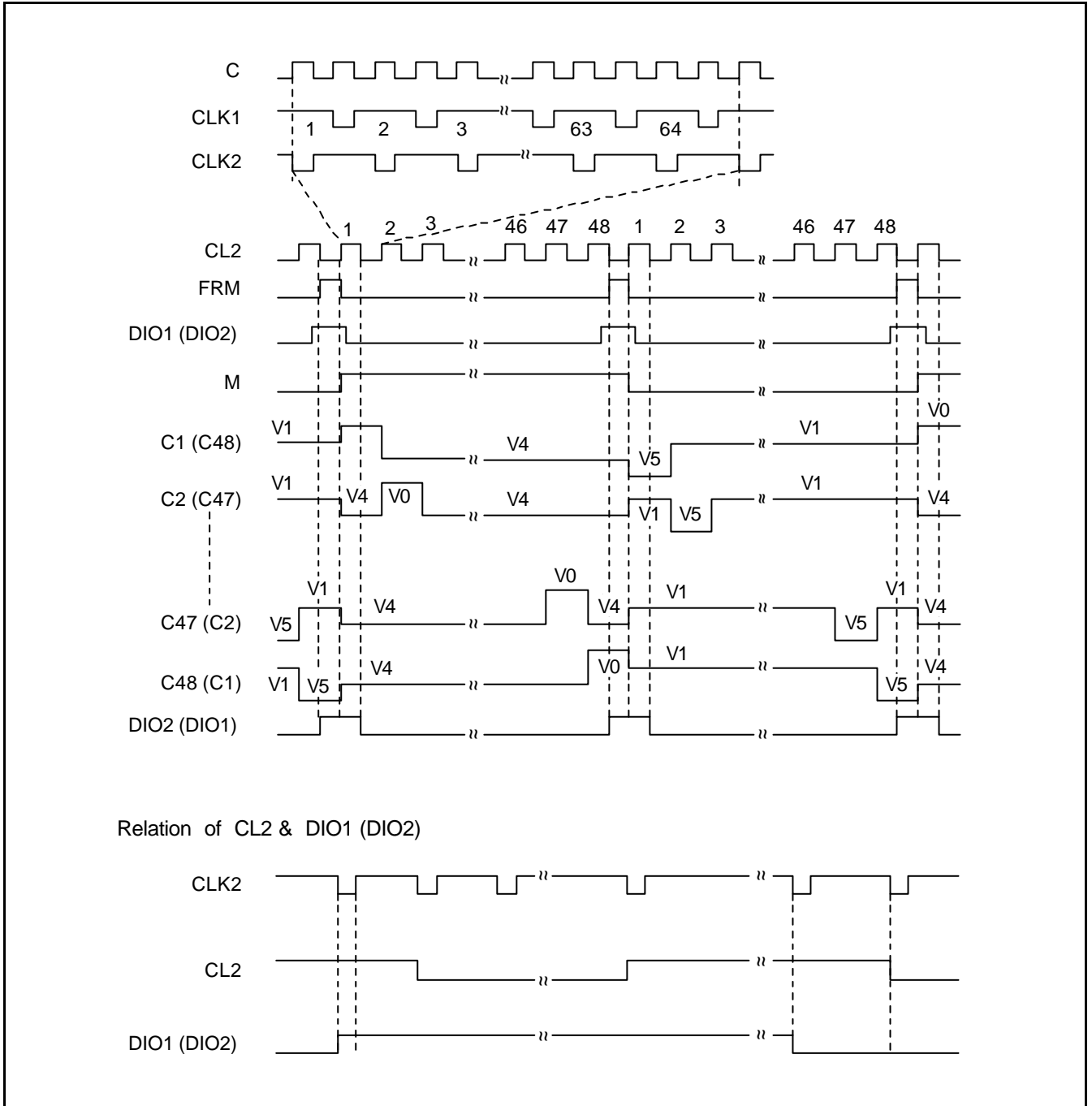

1/128 DUTY TIMING (MASTER MODE)

Condition: DS1 = H, DS2 = H, SHL = H(L), PCLK2 = H

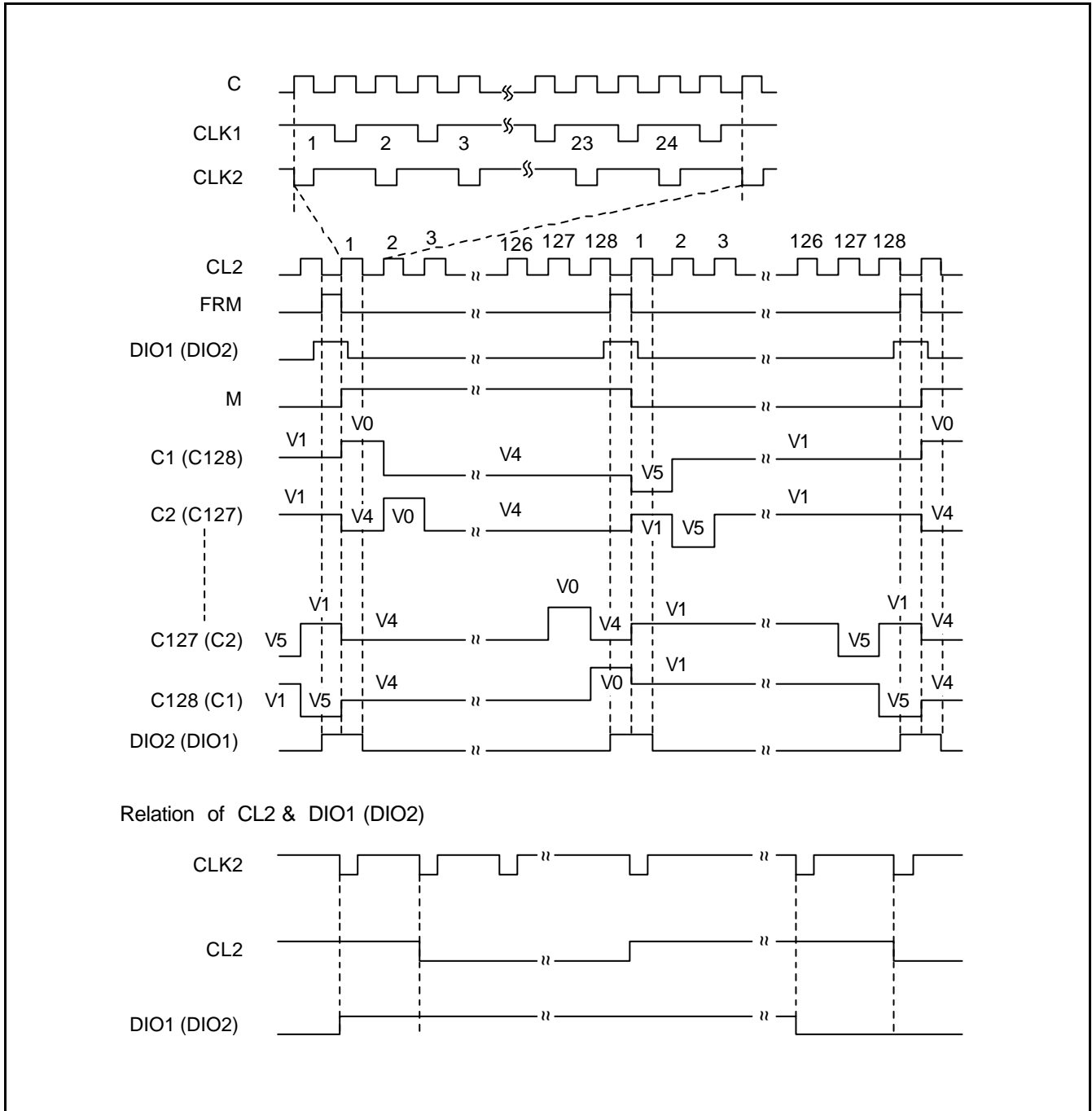

1/48 DUTY TIMING (SLAVE MODE)

Condition: PCLK2 = L, SHL = H(L)

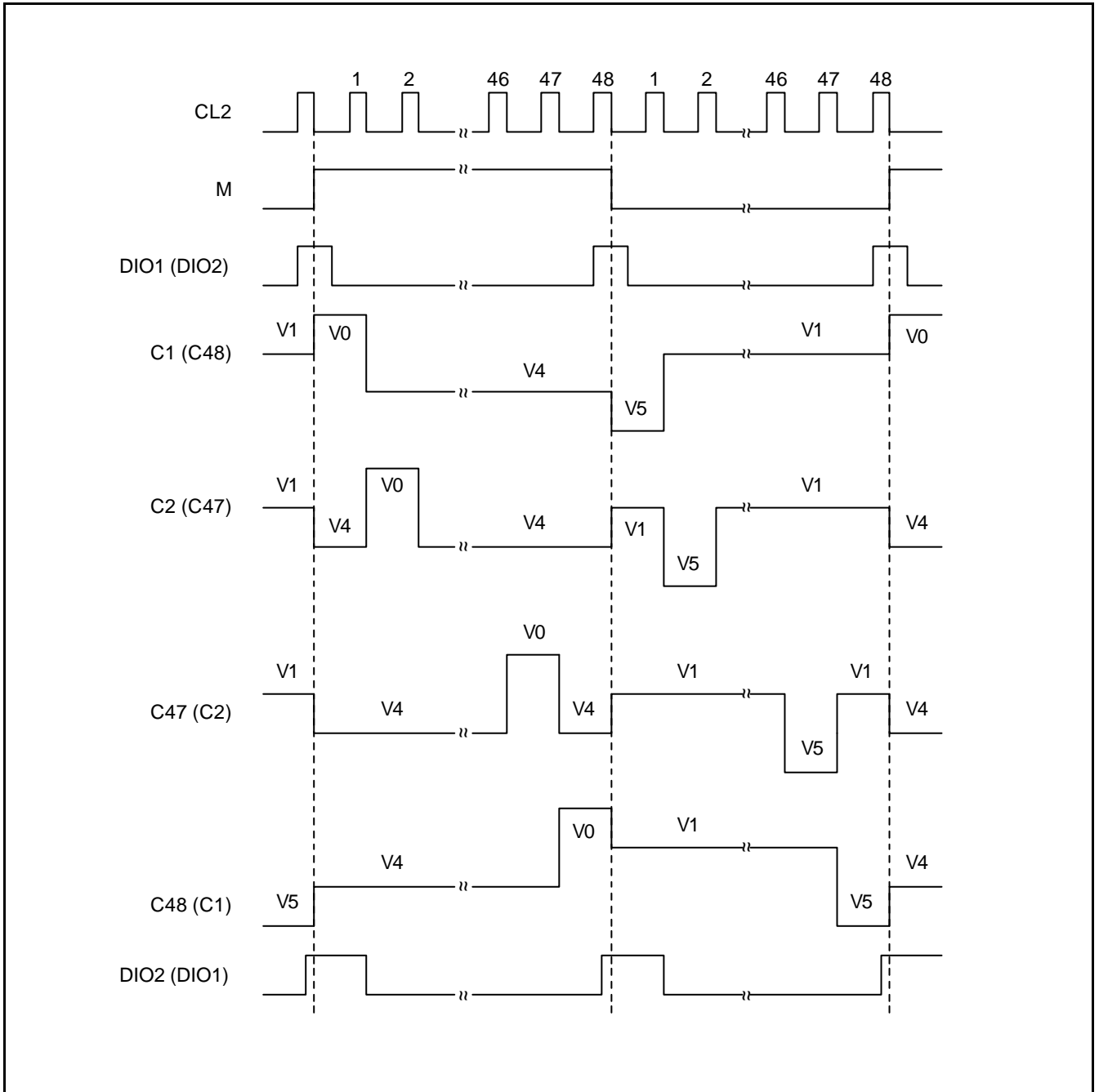

POWER DRIVER CIRCUIT

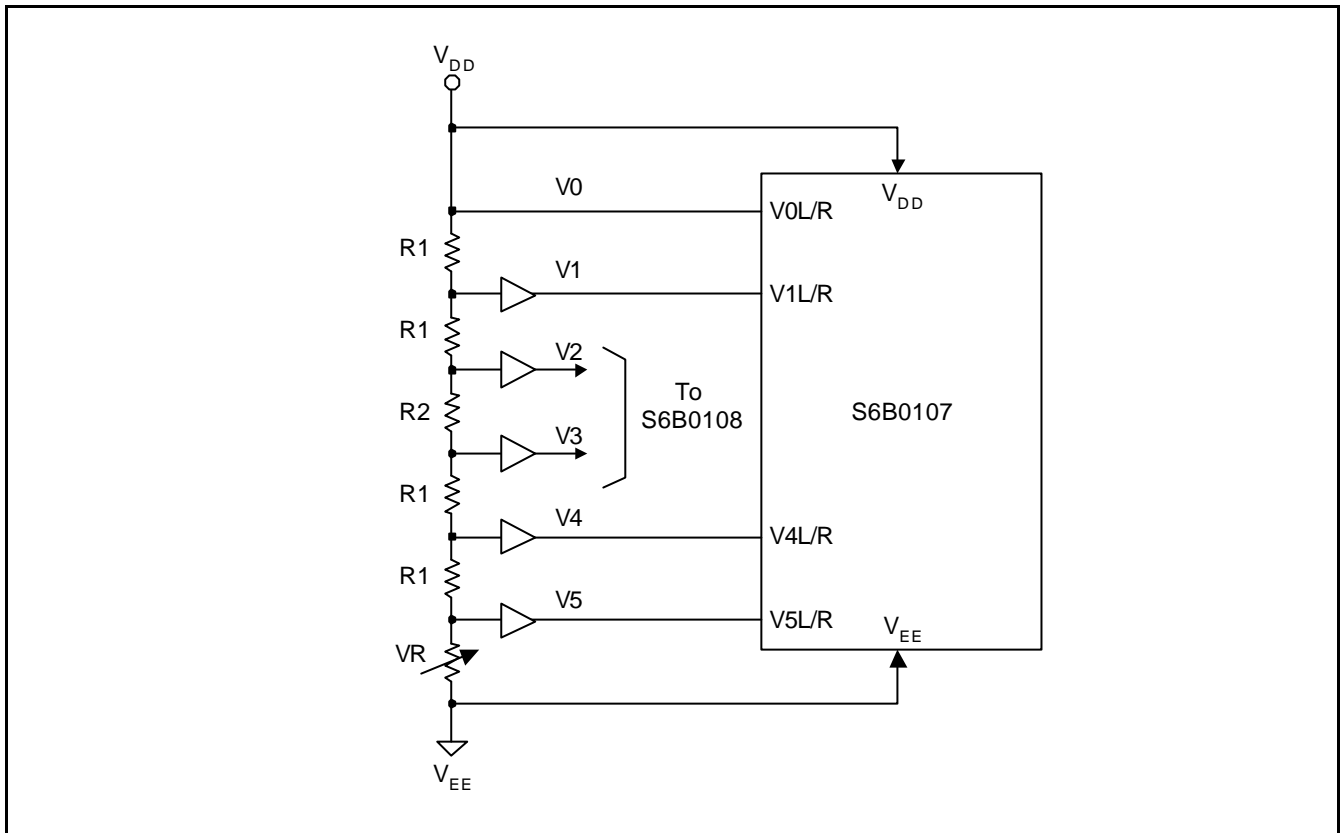

Relation of Duty & Bias

Duty	Bias	RDIV
1/48	1/8	R2 = 4R1
1/64	1/9	R2 = 5R1
1/96	1/11	R2 = 7R1
1/128	1/12	R2 = 8R1

When duty factor is 1/48, the value of R1 & R2 should satisfy.

$$R1/(4R1 + R2) = 1/8$$

$$R1 = 3k\Omega, R2 = 12k\Omega$$

APPLICATION CIRCUIT

1/128 duty segment drive (S6B0108) interface circuit

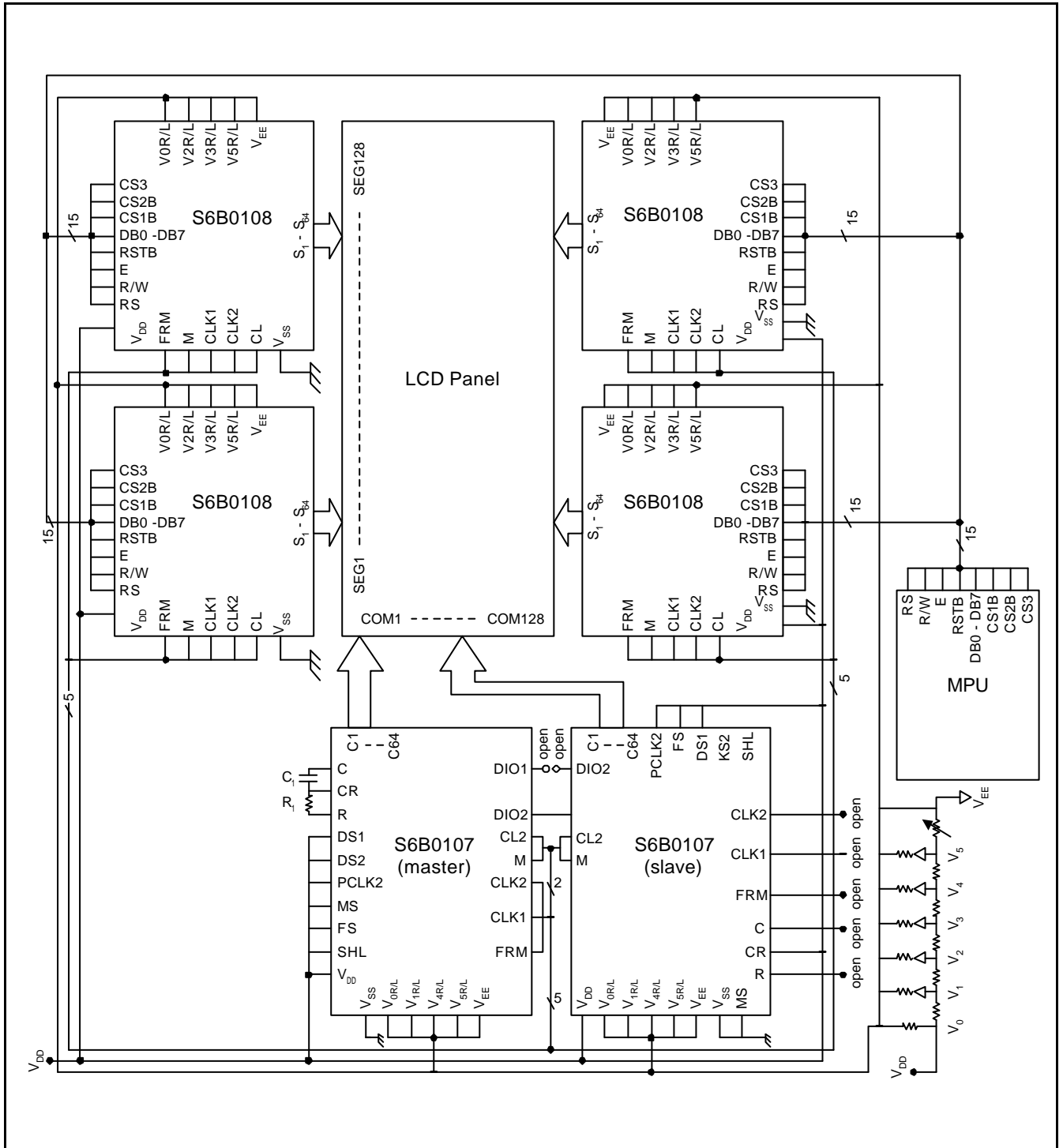



APPENDIX D: SAMSUNG S6B0108 64 CH SEGMENT DRIVER

The complete Samsung's *S6B0108 64 CH Segment Driver for Dot Matrix LCD* specifications follows.

S6B0108

64CH SEGMENT DRIVER FOR DOT MATRIX LCD

July. 2001

Ver. 0.0

Contents in this document are subject to change without notice. No part of this document may be reproduced or transmitted in any form or by any means, electronic or mechanical, for any purpose, without the express written permission of LCD Driver IC Team.

Precautions for Light

Light has characteristics to move electrons in the integrated circuitry of semiconductors, therefore may change the characteristics of semiconductor devices when irradiated with light. Consequently, the users of the packages which may expose chips to external light such as COB, COG, TCP and COF must consider effective methods to block out light from reaching the IC on all parts of the surface area, the top, bottom and the sides of the chip. Follow the precautions below when using the products.

1. Consider and verify the protection of penetrating light to the IC at substrate (board or glass) or product design stage.
2. Always test and inspect products under the environment with no penetration of light.

S6B0755 Specification Revision History		
Version	Content	Date
0.0	Original	July.2001

CONTENTS

INTRODUCTION	1
BLOCK DIAGRAM	2
PIN CONFIGURATION	3
100 QFP.....	3
PAD DIAGRAM (CHIP LAYOUT FOR THE 100QFP).....	4
PAD CENTER COORDINATES (100QFP).....	5
100TQFP (S6B2108).....	6
PAD DIAGRAM (CHIP LAYOUT FOR THE 100TQFP).....	7
PAD CENTER COORDINATES (100TQFP- S6B2108).....	8
PIN DESCRIPTION	9
MAXIMUM ABSOLUTE LIMIT	11
ELECTRICAL CHARACTERISTICS	12
DC CHARACTERISTICS	12
AC CHARACTERISTICS ($V_{DD} = +5V \pm 10\%$, $V_{SS} = 0V$, $T_a = -30$ to $+85^\circ\text{C}$)	13
OPERATING PRINCIPLES AND METHODS	17
I/O BUFFER	17
RESET.....	18
DISPLAY CONTROL INSTRUCTION	21
DISPLAY ON/OFF.....	22
STATUS READ.....	23
APPLICATION CIRCUIT	24
1/64 DUTY COMMON DRIVER (S6B0107) INTERFACE CIRCUIT	24
TIMING DIAGRAM (1/64 DUTY).....	25
LCD PANEL INTERFACE APPLICATION CIRCUIT	26

INTRODUCTION

The S6B0108 (TQFP type: S6B2108) is a LCD driver LSI with 64 channel output for dot matrix liquid crystal graphic display systems. This device consists of the display RAM, 64 bit data latch, 64 bit drivers and decoder logic. It has the internal display RAM for storing the display data transferred from a 8 bit micro controller and generates the dot matrix liquid crystal driving signals corresponding to stored data. The S6B0108 composed of the liquid crystal display system in combination with the S6B0107 (64 channel common driver -TQFP type: S6B2107).

FEATURES

- Dot matrix LCD segment driver with 64 channel output
- Input and output signal
 - Input: 8 bit parallel display data control signal from MPU divided bias voltage (V0R, V0L, V2R, V2L, V3R, V3L, V5R, V5L)
 - Output: 64 channel for LCD driving.
- Display data is stored in display data RAM from MPU.
- Interface RAM
 - Capacity: 512 bytes (4096 bits)
 - RAM bit data: RAM bit data = 1: On
RAM bit data = 0: Off
- Applicable LCD duty: 1/32-1/64
- LCD driving voltage: 8V-17V ($V_{DD}-V_{EE}$)
- Power supply voltage: + 5V \pm 10%
- Interface

Drivers		Controller
Common	Segment	
S6B0107	Other S6B0108	MPU

- High voltage CMOS process
- 100QFP/100TQFP or bare chip available.

BLOCK DIAGRAM

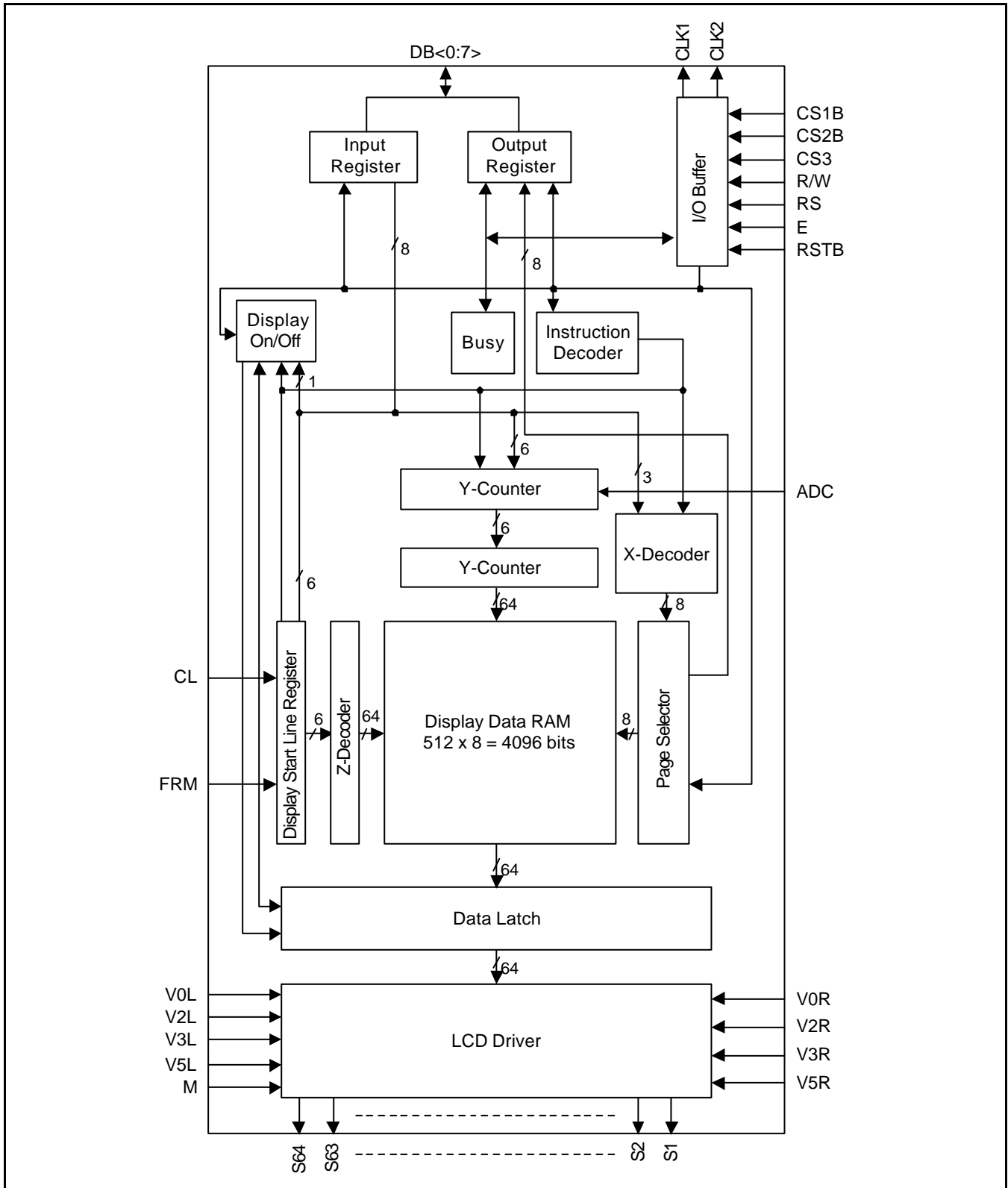

PIN CONFIGURATION

100 QFP

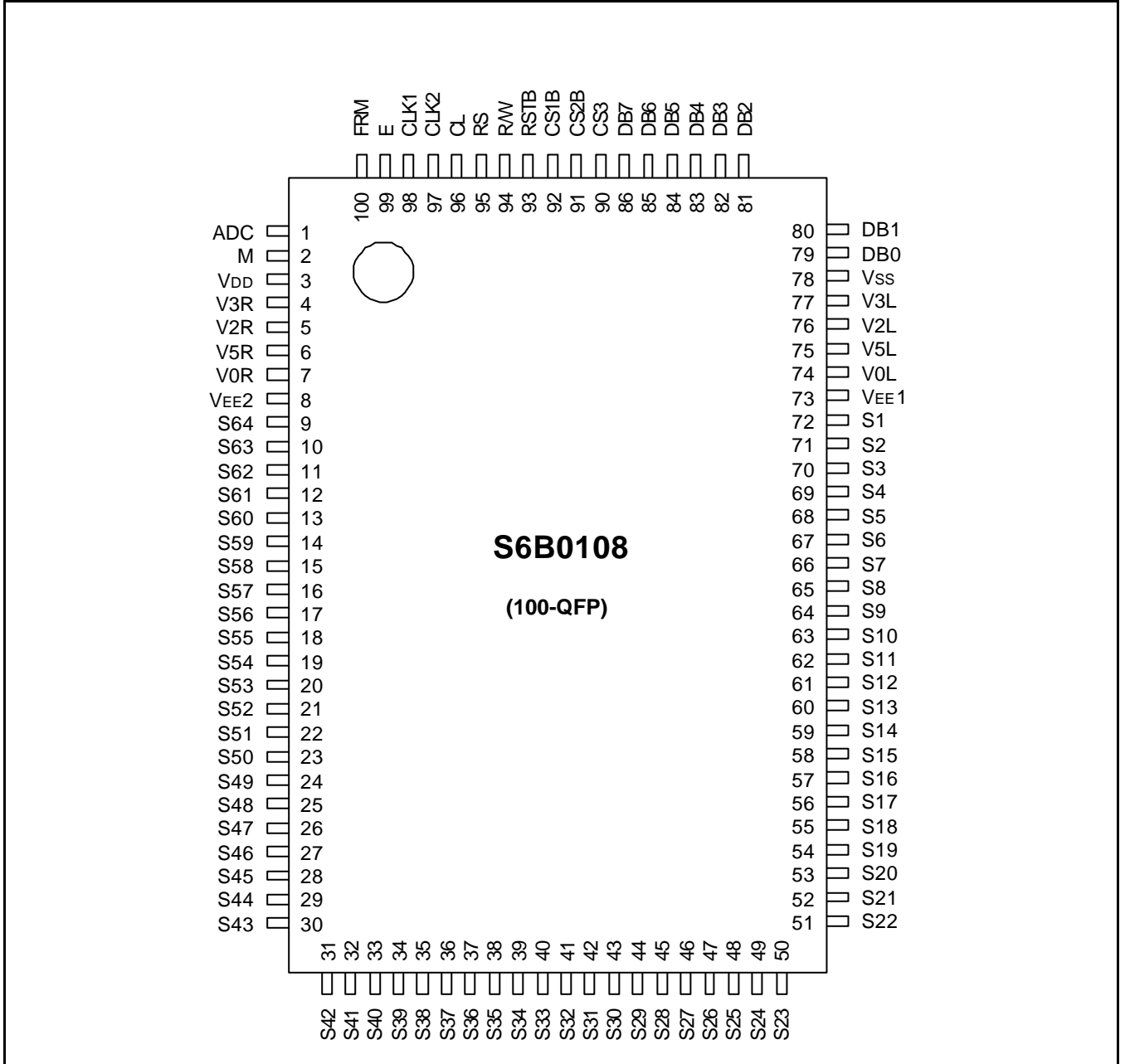

PAD DIAGRAM (CHIP LAYOUT FOR THE 100QFP)

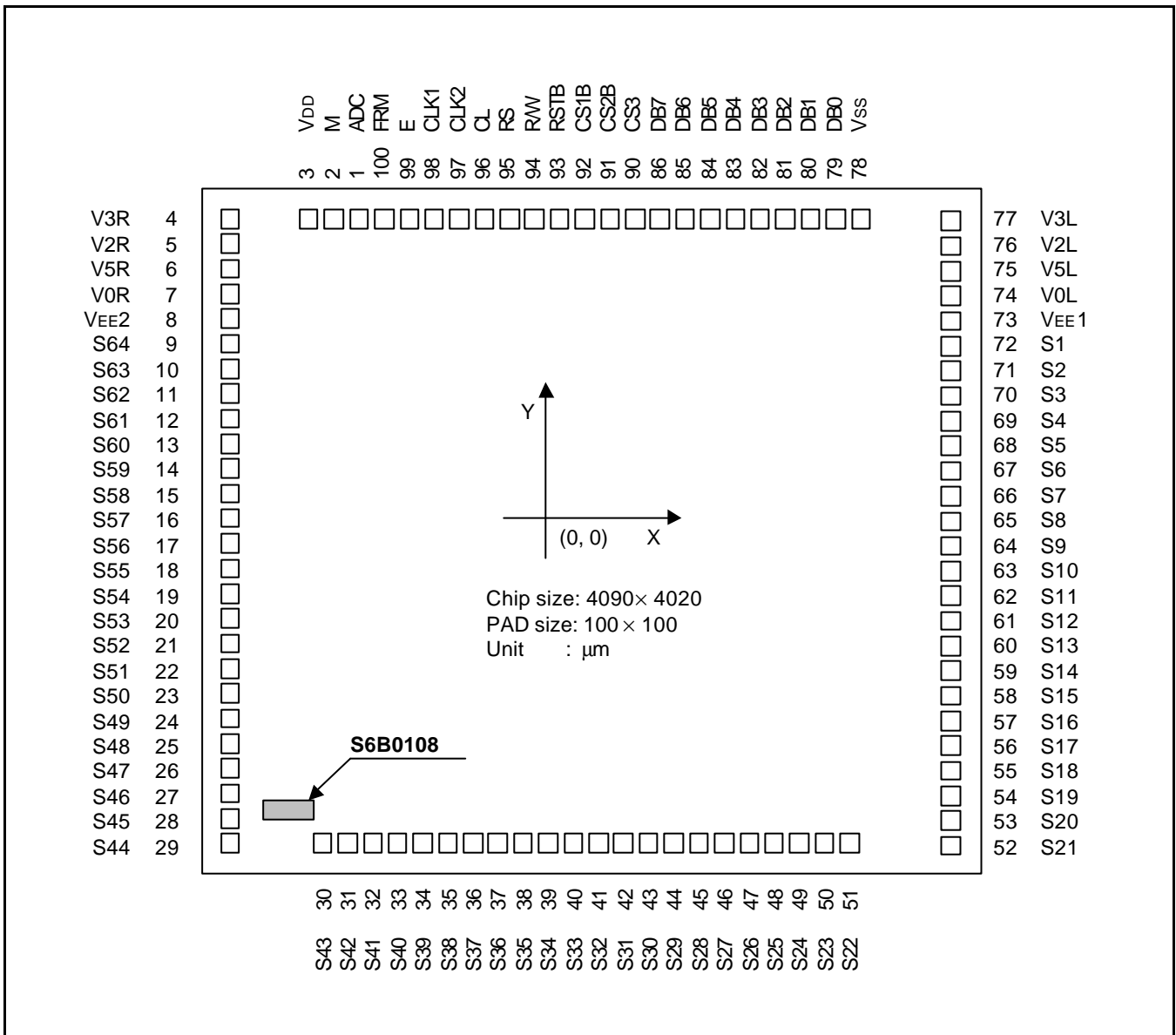

There is mark of S6B0108 on the bottom left in the chip.

PAD CENTER COORDINATES (100QFP)

PAD Number	PAD Name	Coordinate		PAD Number	PAD Name	Coordinate		PAD Number	PAD Name	Coordinate	
		X	Y			X	Y			X	Y
1	ADC	-1140	1845	35	S38	-687	-1845	69	S4	1882	791
2	M	-1275	1845	36	S37	-562	-1845	70	S3	1882	916
3	V _{DD}	-1410	1845	37	S36	-437	-1845	71	S2	1882	1041
4	V3R	-1882	1809	38	S35	-312	-1845	72	S1	1882	1166
5	V2R	-1882	1684	39	S34	-187	-1845	73	V _{EE1}	1882	1310
6	V5R	-1882	1559	40	S33	-62	-1845	74	V0L	1882	1435
7	V0R	-1882	1434	41	S32	62	-1845	75	V5L	1882	1559
8	V _{EE2}	-1882	1309	42	S31	187	-1845	76	V2L	1882	1684
9	S64	-1882	1165	43	S30	312	-1845	77	V3L	1882	1809
10	S63	-1882	1040	44	S29	437	-1845	78	V _{SS}	1412	1845
11	S62	-1882	915	45	S28	562	-1845	79	DB0	1277	1845
12	S61	-1882	790	46	S27	687	-1845	80	DB1	1142	1845
13	S60	-1882	665	47	S26	812	-1845	81	DB2	1007	1845
14	S59	-1882	540	48	S25	937	-1845	82	DB3	882	1845
15	S58	-1882	415	49	S24	1062	-1845	83	DB4	757	1845
16	S57	-1882	290	50	S23	1187	-1845	84	DB5	632	1845
17	S56	-1882	165	51	S22	1487	-1845	85	DB6	507	1845
18	S55	-1882	40	52	S21	1882	-1379	86	DB7	382	1845
19	S54	-1882	-84	53	S20	1882	-1239	90	CS3	245	1845
20	S53	-1882	-209	54	S19	1882	-1099	91	CS2B	120	1845
21	S52	-1882	-334	55	S18	1882	-959	92	CS1B	-5	1845
22	S51	-1882	-459	56	S17	1882	-834	93	RSTB	-130	1845
23	S50	-1882	-584	57	S16	1882	-709	94	R/W	-255	1845
24	S49	-1882	-709	58	S15	1882	-584	95	RS	-380	1845
25	S48	-1882	-834	59	S14	1882	-459	96	CL	-505	1845
26	S47	-1882	-959	60	S13	1882	-334	97	CLK2	-630	1845
27	S46	-1882	-1099	61	S12	1882	-209	98	CLK1	-755	1845
28	S45	-1882	-1239	62	S11	1882	-84	99	E	-880	1845
29	S44	-1882	-1379	63	S10	1882	41	100	FRM	-1005	1845
30	S43	-1487	-1845	64	S9	1882	166				
31	S42	-1187	-1845	65	S8	1882	291				
32	S41	-1062	-1845	66	S7	1882	416				
33	S40	-937	-1845	67	S6	1882	541				
34	S39	-812	-1845	68	S5	1882	666				

100TQFP (S6B2108)

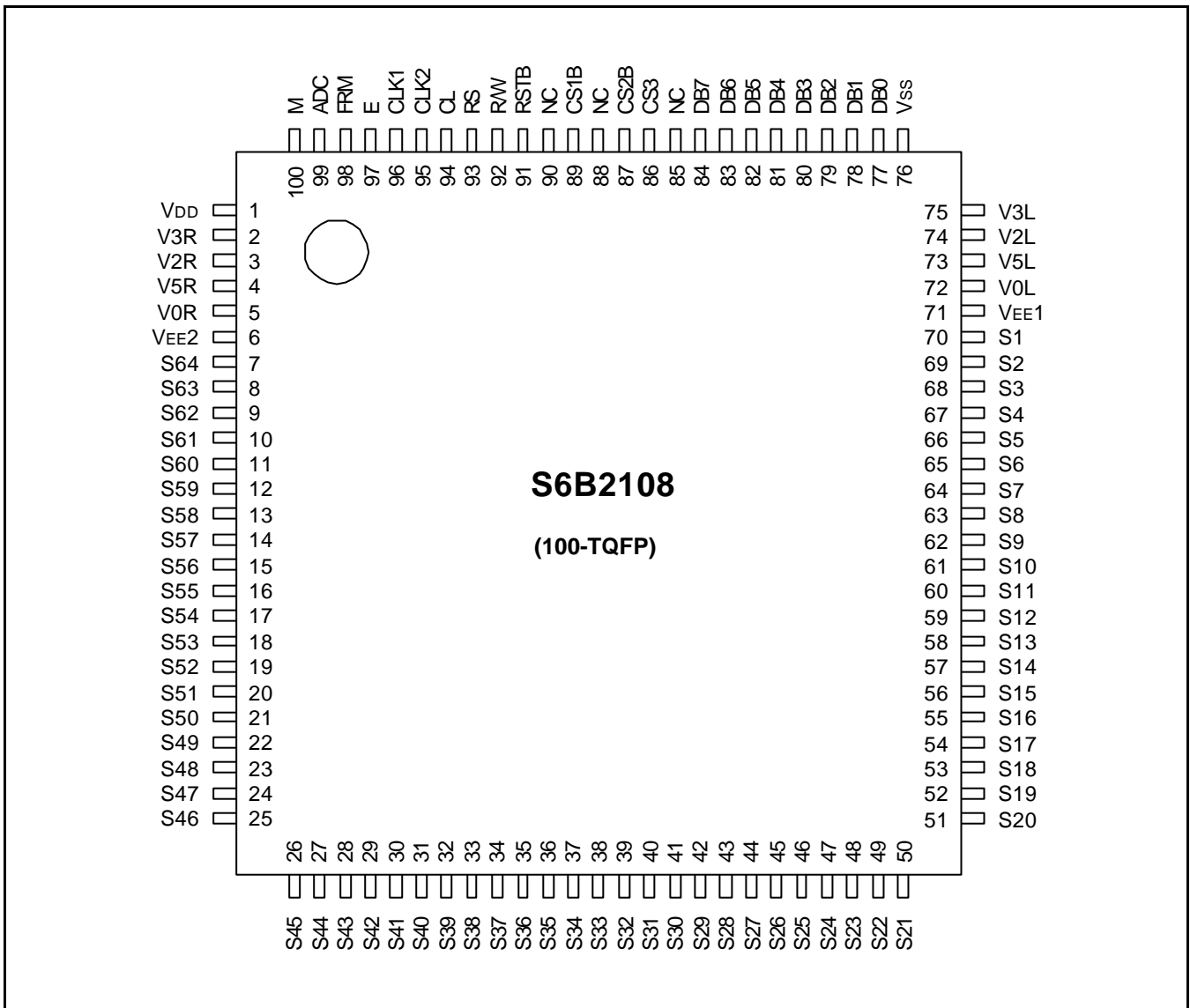

PAD DIAGRAM (CHIP LAYOUT FOR THE 100TQFP)

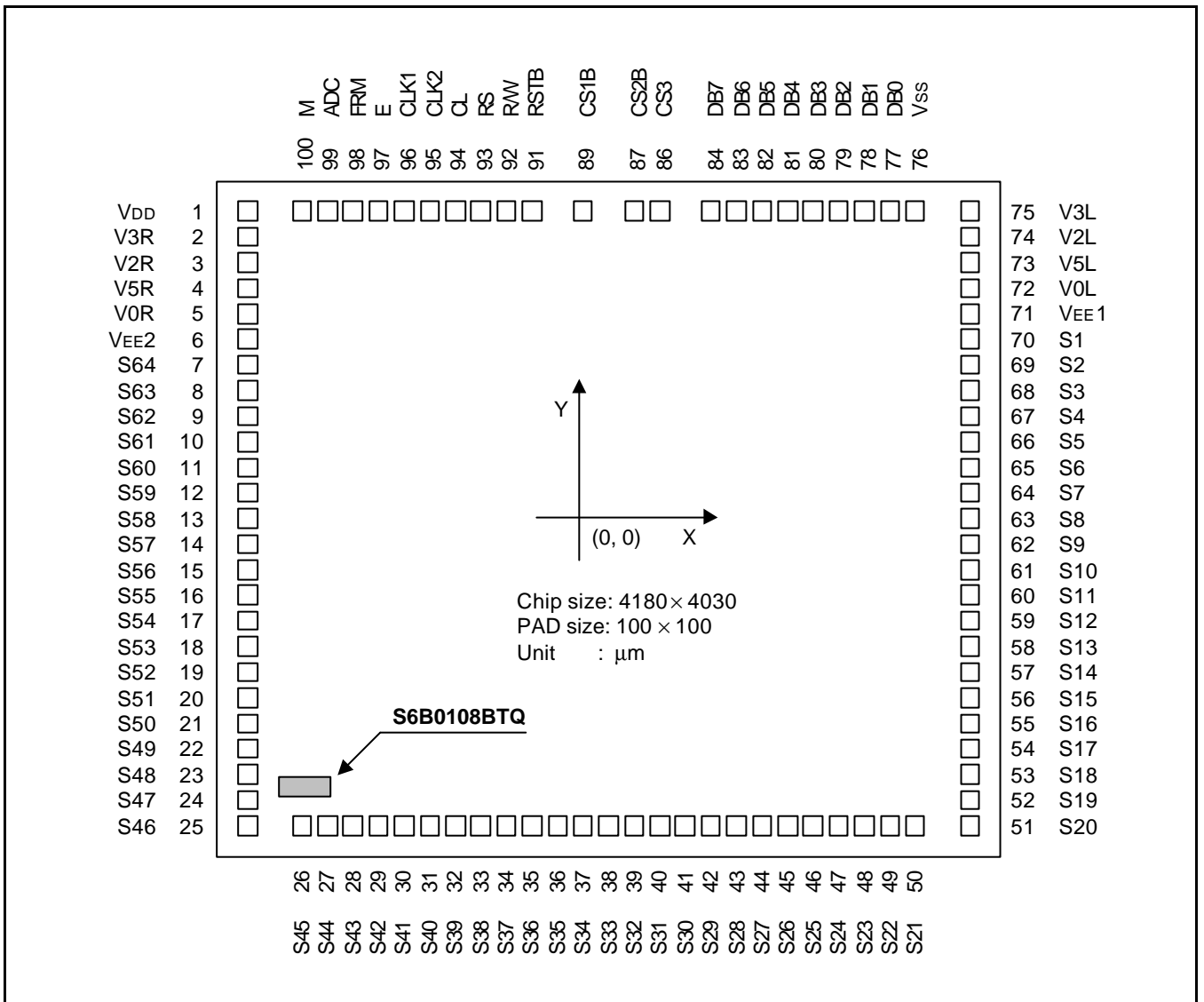

There is mark of S6B2108 on the bottom left in the chip.

PAD CENTER COORDINATES (100TQFP- S6B2108)

PAD Number	PAD Name	Coordinate		PAD Number	PAD Name	Coordinate		PAD Number	PAD Name	Coordinate	
		X	Y			X	Y			X	Y
1	V _{DD}	-1924	1812.5	36	S35	-301.1	-1849	71	V _{EE}	1924	1312.5
2	V3	-1924	1687.5	37	S34	-173.9	-1849	72	V0	1924	1437.5
3	V2	-1924	1562.5	38	S33	-46.7	-1849	73	V5	1924	1562.5
4	V5	-1924	1437.5	39	S32	80.5	-1849	74	V2	1924	1687.5
5	V0	-1924	1312.5	40	S31	207.7	-1849	75	V3	1924	1812.5
6	V _{EE}	-1924	1187.5	41	S30	334.9	-1849	76	V _{SS}	1450.5	1849
7	S64	-1924	1033.2	42	S29	462.1	-1849	77	DB0	1315.5	1849
8	S63	-1924	906	43	S28	589.3	-1849	78	DB1	1180.5	1849
9	S62	-1924	778.8	44	S27	716.5	-1849	79	DB2	1045.5	1849
10	S61	-1924	651.6	45	S26	843.7	-1849	80	DB3	920.5	1849
11	S60	-1924	524.4	46	S25	970.9	-1849	81	DB4	795.5	1849
12	S59	-1924	397.2	47	S24	1098.1	-1849	82	DB5	670.5	1849
13	S58	-1924	270	48	S23	1225.3	-1849	83	DB6	545.5	1849
14	S57	-1924	142.8	49	S22	1352.5	-1849	84	DB7	420.5	1849
15	S56	-1924	15.6	50	S21	1479.7	-1849	85	NC		
16	S55	-1924	-111.6	51	S20	1924	-1245.3	86	CS3	282.8	1849
17	S54	-1924	-238.8	52	S19	1924	-1118.1	87	CS2B	157.8	1849
18	S53	-1924	-366	53	S18	1924	-990.9	88	NC		
19	S52	-1924	-493.2	54	S17	1924	-863.7	89	CS1B	32.8	1849
20	S51	-1924	-620.4	55	S16	1924	-736.5	90	NC		
21	S50	-1924	-747.6	56	S15	1924	-609.3	91	RSTB	-92.2	1849
22	S49	-1924	-874.8	57	S14	1924	-482.1	92	RW	-217.2	1849
23	S48	-1924	-1002	58	S13	1924	-354.9	93	RS	-342.2	1849
24	S47	-1924	-1129.2	59	S12	1924	-227.7	94	CL	467.2	1849
25	S46	-1924	-1256.4	60	S11	1924	-100.5	95	CLK2	-592.2	1849
26	S45	-1573.1	-1849	61	S10	1924	26.7	96	CLK1	-717.2	1849
27	S44	-1445.9	-1849	62	S9	1924	153.9	97	E	-842.2	1849
28	S43	-1318.7	-1849	63	S8	1924	281.1	98	FRW	-967.2	1849
29	S42	-1191.5	-1849	64	S7	1924	408.3	99	ADC	-1177.8	1849
30	S41	-1064.3	-1849	65	S6	1924	535.5	100	M	-1312.8	1849
31	S40	-937.1	-1849	66	S5	1924	662.7				
32	S39	-809.9	-1849	67	S4	1924	789.9				
33	S38	-682.7	-1849	68	S3	1924	917.1				
34	S37	-555.5	-1849	69	S2	1924	1044.3				
35	S36	-428.3	-1849	70	S1	1924	1171.5				

PIN DESCRIPTION

Table 1. Pin Description

Pin Number QFP(TQFP)	Symbol	Input/Output	Description				
3(1) 78(76) 73(71), 8(6)	V_{DD} V_{SS} $V_{EE1,2}$	Power	For internal logic circuit (+5V \pm 10%) GND (0V) For LCD driver circuit $V_{SS} = 0V$, $V_{DD} = +5V \pm 10\%$, $V_{DD} - V_{EE} = 8V - 17V$ V_{EE1} and V_{EE2} is connected by the same voltage.				
74(72), 7(5) 76(74), 5(3) 77(75), 4(2) 75(73), 6(4)	V_{0L} , V_{0R} V_{2L} , V_{2R} V_{3L} , V_{3R} V_{5L} , V_{5R}	Power	Bias supply voltage terminals to drive the LCD. <table border="1" style="margin-left: auto; margin-right: auto;"> <thead> <tr> <th>Select Level</th> <th>Non-Select Level</th> </tr> </thead> <tbody> <tr> <td>$V_{0L(R)}$, $V_{5L(R)}$</td> <td>$V_{2L(R)}$, $V_{3L(R)}$</td> </tr> </tbody> </table> V_{0L} and V_{0R} (V_{2L} & V_{2R} , V_{3L} & V_{3R} , V_{5L} & V_{5R}) should be connected by the same voltage.	Select Level	Non-Select Level	$V_{0L(R)}$, $V_{5L(R)}$	$V_{2L(R)}$, $V_{3L(R)}$
Select Level	Non-Select Level						
$V_{0L(R)}$, $V_{5L(R)}$	$V_{2L(R)}$, $V_{3L(R)}$						
92(89) 91(87) 90(86)	CS1B CS2B CS3	Input	Chip selection In order to interface data for input or output, the terminals have to be CS1B = L, CS2B = L, and CS3 = H.				
2(100)	M	Input	Alternating signal input for LCD driving.				
1(99)	ADC	Input	Address control signal to determine the relation between Y address of display RAM and terminals from which the data is output. ADC = H \rightarrow Y0: S1 - Y63: S64 ADC = L \rightarrow Y0: S64 - Y63: S1				
100(98)	FRM	Input	Synchronous control signal. Presets the 6-bit Z counter and synchronizes the common signal with the frame signal when the frame signal becomes high.				
99(97)	E	Input	Enable signal. Write mode (R/W = L) \rightarrow data of DB<0:7> is latched at the falling edge of E. Read mode (R/W = H) \rightarrow DB<0:7> appears the reading data while E is at high level.				
98(96) 97(95)	CLK1 CLK2	Input	2 phase clock signal for internal operation. Used to execute operations for input/output of display RAM data and others.				
96(94)	CL	Input	Display synchronous signal. Display data is latched at rising time of the CL signal and increments the Z-address counter at the CL falling time.				
95(93)	RS	Input	Data or Instruction. RS = H \rightarrow DB<0:7>: Display RAM data RS = L \rightarrow DB<0:7>: Instruction data				

Table 1. Pin Description (Continued)

Pin Number QFP(TQFP)	Symbol	Input/Output	Description													
94(92)	R/W	Input	Read or Write. R/W = H → Data appears at DB<0:7> and can be read by the CPU while E = H, CS1B = L, CS2B = L and CS3 = H . R/W = L → Display data DB<0:7> can be written at falling of E when CS1B = L, CS2B = L and CS3 = H.													
79-86 (77-84)	DB0-DB7	Input/Output	Data bus. There state I/O common terminal.													
72-9 (70-7)	S1-S64	Output	LCD segment driver output. Display RAM data 1: On Display RAM data 0: Off (relation of display RAM data & M) <table border="1" data-bbox="699 808 1153 999"> <thead> <tr> <th>M</th> <th>Data</th> <th>Output Level</th> </tr> </thead> <tbody> <tr> <td rowspan="2">L</td> <td>L</td> <td>V₂</td> </tr> <tr> <td>H</td> <td>V₀</td> </tr> <tr> <td rowspan="2">H</td> <td>L</td> <td>V₃</td> </tr> <tr> <td>H</td> <td>V₅</td> </tr> </tbody> </table>	M	Data	Output Level	L	L	V ₂	H	V ₀	H	L	V ₃	H	V ₅
M	Data	Output Level														
L	L	V ₂														
	H	V ₀														
H	L	V ₃														
	H	V ₅														
93(91)	RSTB	Input	Reset signal. When RSTB=L, <ul style="list-style-type: none"> - ON/OFF register becomes set by 0. (display off) - Display start line register becomes set by 0 (Z-address 0 set, display from line 0) After releasing reset, this condition can be changed only by instruction.													
87(85), 88(88) 89(90)	NC		No connection. (open)													

MAXIMUM ABSOLUTE LIMIT

Characteristic	Symbol	Value	Unit	Note
Operating voltage	V_{DD}	-0.3 to +7.0	V	(1)
Supply voltage	V_{EE}	$V_{DD}-19.0$ to $V_{DD}+0.3$	V	(4)
Driver supply voltage	V_B	-0.3 to $V_{DD}+0.3$	V	(1), (3)
	V_{LCD}	$V_{EE}-0.3$ to $V_{DD}+0.3$	V	(2)
Operating temperature	T_{OPR}	-30 to +85	°C	
Storage temperature	T_{STG}	-55 to +125	°C	

NOTES:

1. Based on $V_{SS} = 0V$.
2. Applies the same supply voltage to V_{EE1} and V_{EE2} . $V_{LCD} = V_{DD} - V_{EE}$.
3. Applies to M, FRM, CL, RSTB, ADC, CLK1, CLK2, CS1B, CS2B, CS3, E, R/W, RS and DB0 - DB7.
4. Applies to V0L(R), V2L(R), V3L(R) and V5L(R).
Voltage level: $V_{DD} \geq V0L = V0R \geq V2L = V2R \geq V3L = V3R \geq V5L = V5R \geq V_{EE}$.

ELECTRICAL CHARACTERISTICS

DC CHARACTERISTICS

($V_{DD} = +5V \pm 10\%$, $V_{SS} = 0V$, $V_{DD} - V_{EE} = 8$ to $17V$, $T_a = -30$ to $+85^\circ C$)

Characteristic	Symbol	Condition	Min	Typ	Max	Unit	Note
Input high voltage	V_{IH1}	–	$0.7V_{DD}$	–	V_{DD}	V	(1)
	V_{IH2}	–	2.0	–	V_{DD}	V	(2)
Input low voltage	V_{IL1}	–	0	–	$0.3V_{DD}$	V	(1)
	V_{IL2}	–	0	–	0.8	V	(2)
Output high voltage	V_{OH}	$I_{OH} = -200\mu A$	2.4	–	–	V	(3)
Output low voltage	V_{OL}	$I_{OL} = 1.6mA$	–	–	0.4	V	(3)
Input leakage current	I_{LKG}	$V_{IN} = V_{SS} - V_{DD}$	-1.0	–	1.0	μA	(4)
Three-state(off) input current	I_{TSL}	$V_{IN} = V_{SS} - V_{DD}$	-5.0	–	5.0	μA	(5)
Driver input leakage current	I_{DIL}	$V_{IN} = V_{EE} - V_{DD}$	-2.0	–	2.0	μA	(6)
Operating current	I_{DD1}	During display	–	–	100	μA	(7)
	I_{DD2}	During access Access cycle = 1MHz	–	–	500	μA	(7)
On resistance	R_{ON}	$V_{DD} - V_{EE} = 15V$ $I_{LOAD} = \pm 0.1mA$	–	–	7.5	$K\Omega$	(8)

NOTES:

1. CL, FRM, M, RSTB, CLK1, CLK2
2. CS1B, CS2B, CS3, E, R/W, RS, DB0 - DB7
3. DB0 - DB7
4. Except DB0 - DB7
5. DB0 - DB7 at high impedance
6. V0L(R), V2L(R), V3L(R), V5L(R)
7. 1/64 duty, FCLK = 250kHz, frame frequency = 70HZ, output: no load
8. $V_{DD} - V_{EE} = 15.5V$
 $V0L(R) > V2L(R) = V_{DD} - 2/7 (V_{DD} - V_{EE}) > V3L(R) = V_{EE} + 2/7 (V_{DD} - V_{EE}) > V5L(R)$

AC CHARACTERISTICS ($V_{DD} = +5V \pm 10\%$, $V_{SS} = 0V$, $T_a = -30$ to $+85^\circ C$)

Clock Timing

Characteristic	Symbol	Min	Typ	Max	Unit
CLK1, CLK2 cycle time	t_{CY}	2.5	–	20	μs
CLK1 "low" level width	t_{WL1}	625	–	–	ns
CLK2 "low" level width	t_{WL2}	625	–	–	
CLK1 "high" level width	t_{WH1}	1875	–	–	
CLK2 "high" level width	t_{WH2}	1875	–	–	
CLK1-CLK2 phase difference	t_{D12}	625	–	–	
CLK2-CLK1 phase difference	t_{D21}	625	–	–	
CLK1, CLK2 rise time	t_R	–	–	150	
CLK1, CLK2 fall time	t_F	–	–	150	

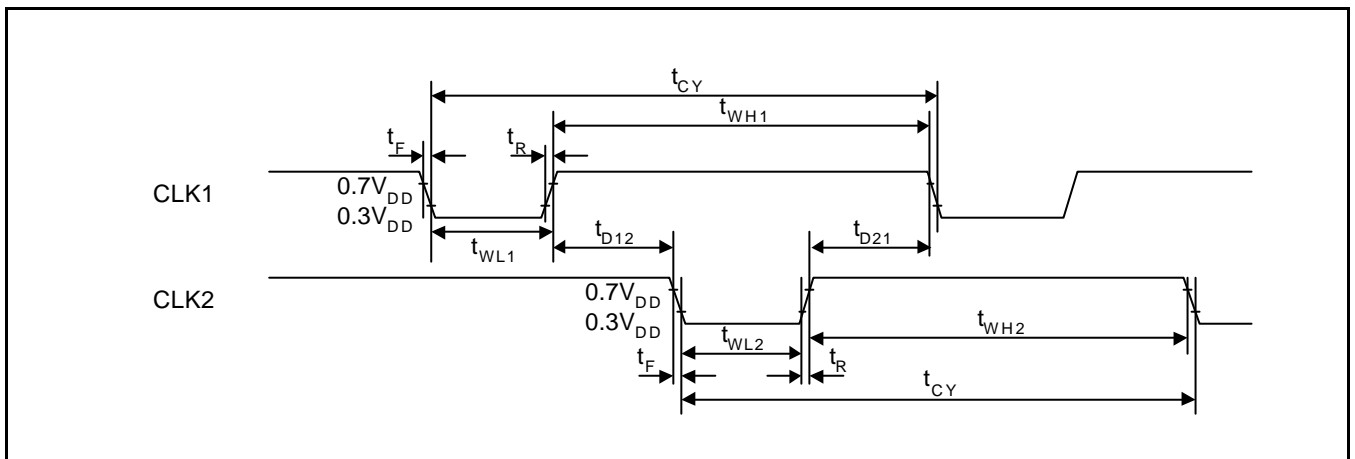

Figure 1. External Clock Waveform

Display Control Timing

Characteristic	Symbol	Min	Typ	Max	Unit
FRM delay time	t_{DF}	-2	-	+2	us
M delay time	t_{DM}	-2	-	+2	us
CL "low" level width	t_{WL}	35	-	-	us
CL "high" level width	t_{WH}	35	-	-	us

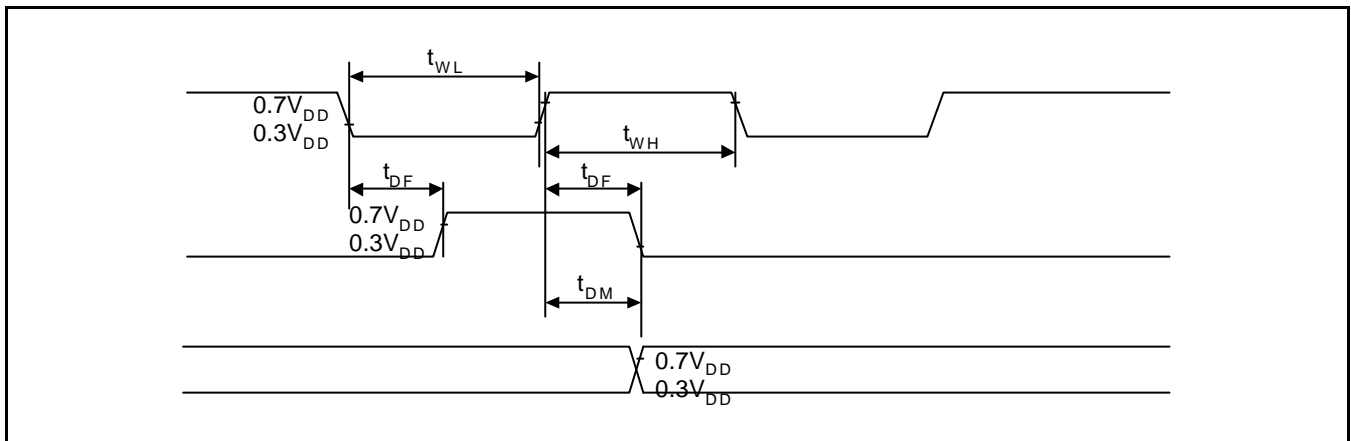

Figure 2. Display Control Waveform

MPU Interface

Characteristic	Symbol	Min	Typ	Max	Unit
E cycle	t_C	1000	–	–	ns
E high level width	t_{WH}	450	–	–	ns
E low level width	t_{WL}	450	–	–	ns
E rise time	t_R	–	–	25	ns
E fall time	t_F	–	–	25	ns
Address set-up time	t_{ASU}	140	–	–	ns
Address hold time	t_{AH}	10	–	–	ns
Data set-up time	t_{DSU}	200	–	–	ns
Data delay time	t_D	–	–	320	ns
Data hold time (write)	t_{DHW}	10	–	–	ns
Data hold time (read)	t_{DHR}	20	–	–	ns

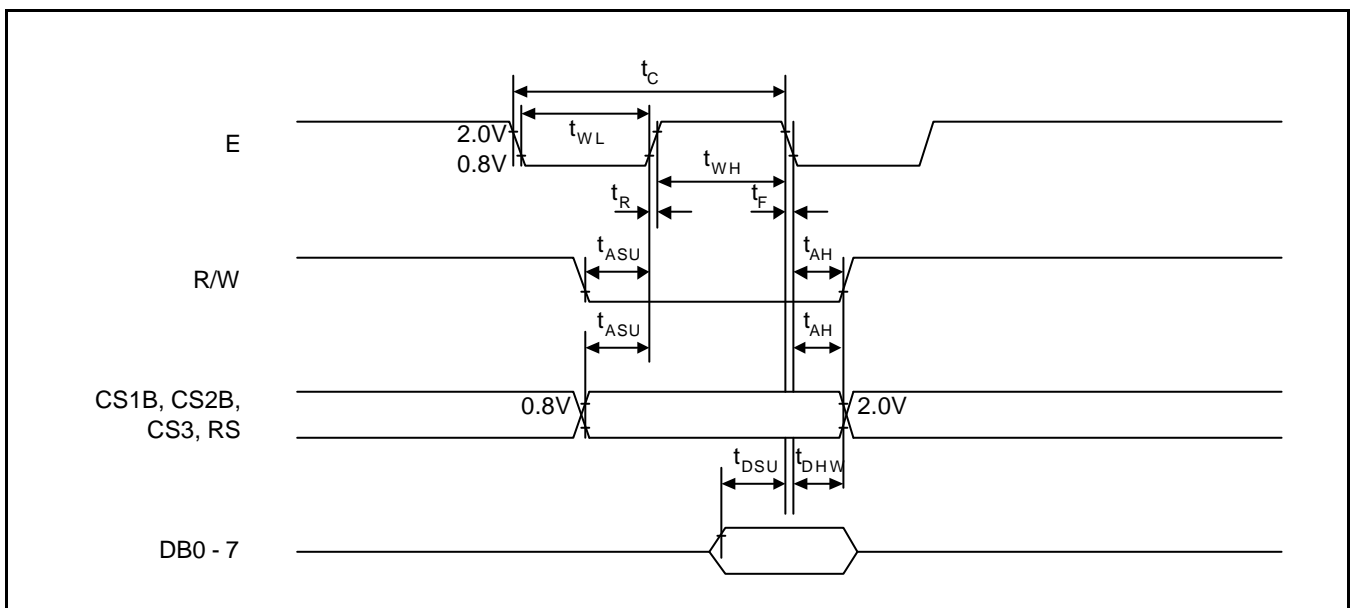

Figure 3. MPU Write Timing

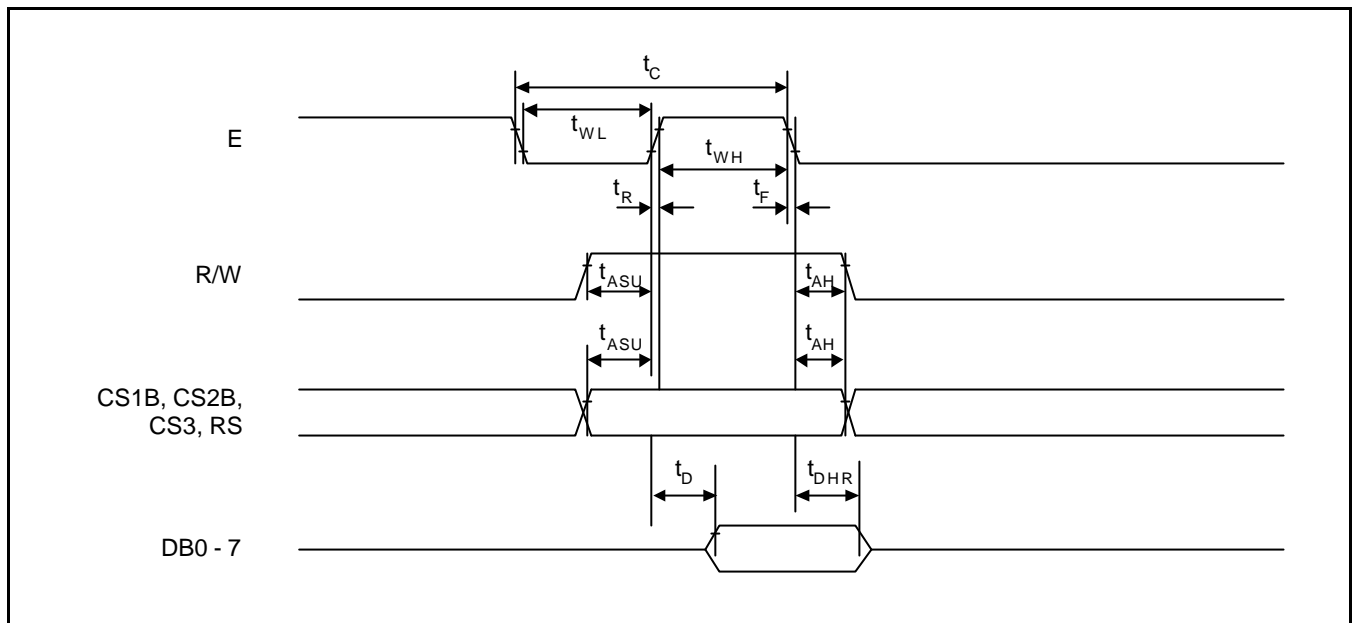

Figure 4. MPU Read Timing

OPERATING PRINCIPLES AND METHODS

I/O BUFFER

Input buffer controls the status between the enable and disable of chip. Unless the CS1B to CS3 is in active mode, Input or output of data and instruction does not execute. Therefore internal state is not change. But RSTB and ADC can operate regardless CS1B-CS3.

INPUT REGISTER

Input register is provided to interface with MPU which is different operating frequency. Input register stores the data temporarily before writing it into display RAM. When CS1B to CS3 are in the active mode, R/W and RS select the input register. The data from MPU is written into input register. Then Writing it into display RAM. Data latched for falling of the E signal and write automatically into the display data RAM by internal operation.

OUTPUT REGISTER

Output register stores the data temporarily from display data RAM when CS1B, CS2B and CS3 are in active mode and R/W and RS = H, stored data in display data RAM is latched in output register. When CS1B to CS3 is in active mode and R/W = H, RS = L, status data (busy check) can read out. To read the contents of display data RAM, twice access of read instruction is needed. In first access, data in display data RAM is latched into output register. In second access, MPU can read data which is latched. That is, to read the data in display data RAM, it needs dummy read. But status read is not needed dummy read.

RS	R/W	Function
L	L	Instruction
	H	Status read (busy check)
H	L	Data write (from input register to display data RAM)
	H	Data read (from display data RAM to output register)

RESET

The system can be initialized by setting RSTB terminal at low level when turning power on, receiving instruction from MPU.

When RSTB becomes low, following procedure is occurred.

- Display off
- Display start line register become set by 0. (Z-address 0)

While RSTB is low, No instruction except status read can be accepted. Therefore, execute other instructions after making sure that DB4 = 0 (clear RSTB) and DB7 = 0 (ready) by status read instruction. The Conditions of power supply at initial power up are shown in Table 2.

Table 2. Power Supply Initial Conditions

Item	Symbol	Min	Typ	Max	Unit
Reset time	t_{RS}	1.0	—	—	us
Rise time	t_R	—	—	200	ns

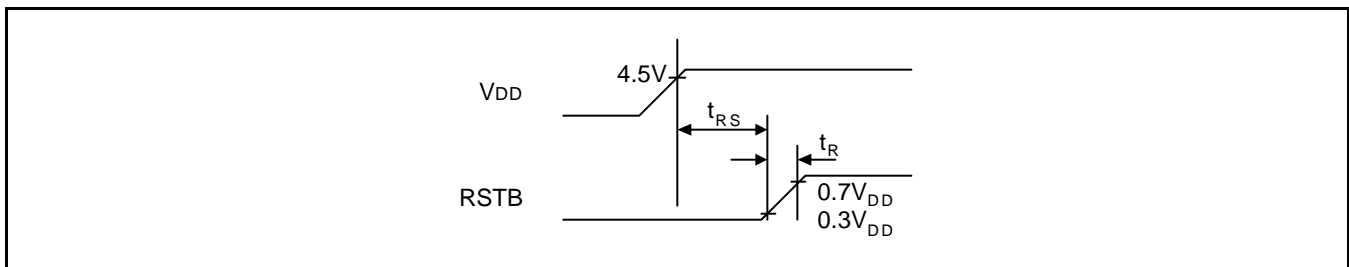

Busy Flag

Busy Flag indicates that S6B0108 is operating or no operating. When busy flag is high, S6B0108 is in internal operating. When busy flag is low, S6B0108 can accept the data or instruction. DB7 indicates busy flag of the S6B0108.

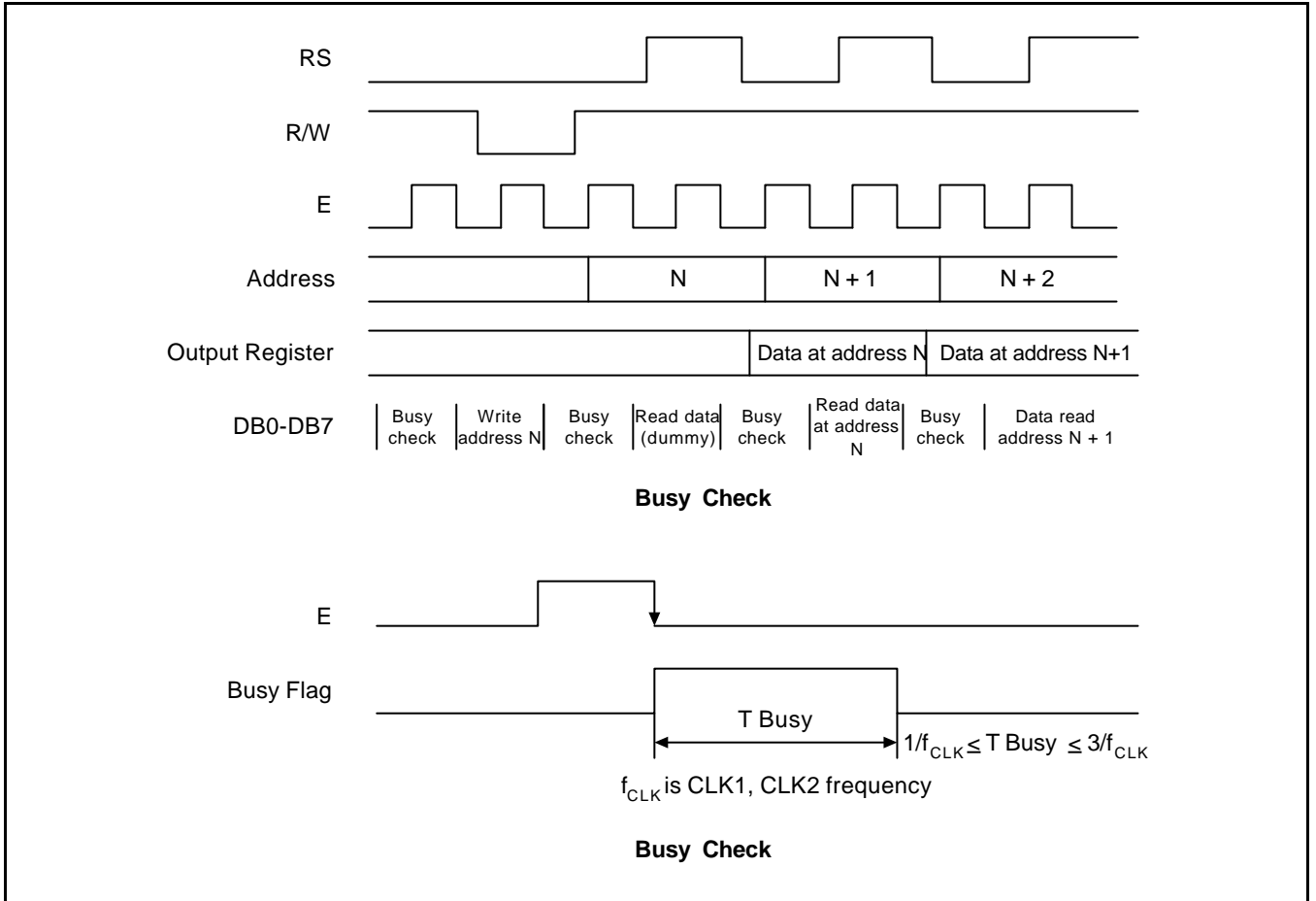

Display ON/OFF Flip - Flop

The display on/off flip-flop makes on/off the liquid crystal display. When flip-flop is reset (logical low), selective voltage or non selective voltage appears on segment output terminals. When flip-flop is set (logic high), non selective voltage appears on segment output terminals regardless of display RAM data. The display on/off flip-flop can changes status by instruction. The display data at all segment disappear while RSTB is low. The status of the flip-flop is output to DB5 by status read instruction. The display on/off flip-flop synchronized by CL signal.

X Page Register

X page register designates pages of the internal display data RAM. Count function is not available. An address is set by instruction.

Y Address Counter

Y address counter designates address of the internal display data RAM. An address is set by instruction and is increased by 1 automatically by read or write operations of display data.

Display Data RAM

Display data RAM stores a display data for liquid crystal display. To indicate on state dot matrix of liquid crystal display, write data 1. The other way, off state, writes 0.

Display data RAM address and segment output can be controlled by ADC signal.

- ADC = H → Y-address 0:S1 - Y address 63:S64
- ADC = L → Y-address 0:S64 - Y address 63:S1

ADC terminal connect the V_{DD} or V_{SS} .

Display Start Line Register

The display start line register indicates of display data RAM to display top line of liquid crystal display. Bit data (DB<0:5>) of the display start line set instruction is latched in display start line register. Latched data is transferred to the Z address counter while FRM is high, presetting the Z address counter. It is used for scrolling of the liquid crystal display screen.

DISPLAY CONTROL INSTRUCTION

The display control instructions control the internal state of the S6B0108. Instruction is received from MPU to S6B0108 for the display control. The following table shows various instructions.

Instruction	RS	R/W	DB7	DB6	DB5	DB4	DB3	DB2	DB1	DB0	Function	
Display on/off	L	L	L	L	H	H	H	H	H	L/H	Controls the display on or off. Internal status and display RAM data is not affected. L: OFF, H: ON	
Set address (Y address)	L	L	L	H	Y address (0 - 63)						Sets the Y address in the Y address counter.	
Set page (X address)	L	L	H	L	H	H	H	Page (0 - 7)			Sets the X address at the X address register.	
Display start line (Z address)	L	L	H	H	Display start line (0 - 63)						Indicates the display data RAM displayed at the top of the screen.	
Status read	L	H	Busy	L	On/Off	Reset	L	L	L	L	Read status. BUSY L: Ready H: In operation ON/OFF L: Display ON H: Display OFF RESET L: Normal H: Reset	
Write display data	H	L	Write data									Writes data (DB0:7) into display data RAM. After writing instruction, Y address is increased by 1 automatically.
Read display data	H	H	Read data									Reads data (DB0:7) from display data RAM to the data bus.

DISPLAY ON/OFF

RS	R/W	DB7	DB6	DB5	DB4	DB3	DB2	DB1	DB0
0	0	0	0	1	1	1	1	1	D

The display data appears when D is 1 and disappears when D is 0. Though the data is not on the screen with D = 0, it remains in the display data RAM. Therefore, you can make it appear by changing D = 0 into D = 1.

SET ADDRESS (Y ADDRESS)

S	R/W	DB7	DB6	DB5	DB4	DB3	DB2	DB1	DB0
0	0	0	1	AC5	AC4	AC3	AC2	AC1	AC0

Y address (AC0 - AC5) of the display data RAM is set in the Y address counter. An address is set by instruction and increased by 1 automatically by read or write operations of display data.

SET PAGE (X ADDRESS)

RS	R/W	DB7	DB6	DB5	DB4	DB3	DB2	DB1	DB0
0	0	1	0	1	1	1	AC2	AC1	AC0

X address(AC0 - AC2) of the display data RAM is set in the X address register. Writing or reading to or from MPU is executed in this specified page until the next page is set.

DISPLAY START LINE (Z ADDRESS)

RS	R/W	DB7	DB6	DB5	DB4	DB3	DB2	DB1	DB0
0	0	1	1	AC5	AC4	AC3	AC2	AC1	AC0

Z address (AC0 - AC5) of the display data RAM is set in the display start line register and displayed at the top of the screen. When the display duty cycle is 1/64 or others(1/32 - 1/64), the data of total line number of LCD screen, from the line specified by display start line instruction, is displayed.

STATUS READ

RS	R/W	DB7	DB6	DB5	DB4	DB3	DB2	DB1	DB0
0	1	BUSY	0	ON/OFF	RESET	0	0	0	0

- **BUSY**
When BUSY is 1, the Chip is executing internal operation and no instructions are accepted.
When BUSY is 0, the Chip is ready to accept any instructions.
- **ON/OFF**
When ON/OFF is 1, the display is off.
When ON/OFF is 0, the display is on.
- **RESET**
When RESET is 1, the system is being initialized.
In this condition, no instructions except status read can be accepted.
When RESET is 0, initializing has finished and the system is in the usual operation condition.

WRITE DISPLAY DATA

RS	R/W	DB7	DB6	DB5	DB4	DB3	DB2	DB1	DB0
1	0	D7	D6	D5	D4	D3	D2	D1	D0

Writes data (D0 - D7) into the display data RAM. After writing instruction, Y address is increased by 1 automatically.

READ DISPLAY DATA

RS	R/W	DB7	DB6	DB5	DB4	DB3	DB2	DB1	DB0
1	1	D7	D6	D5	D4	D3	D2	D1	D0

Reads data (D0 - D7) from the display data RAM. After reading instruction, Y address is increased by 1 automatically.

APPLICATION CIRCUIT

1/64 DUTY COMMON DRIVER (S6B0107) INTERFACE CIRCUIT

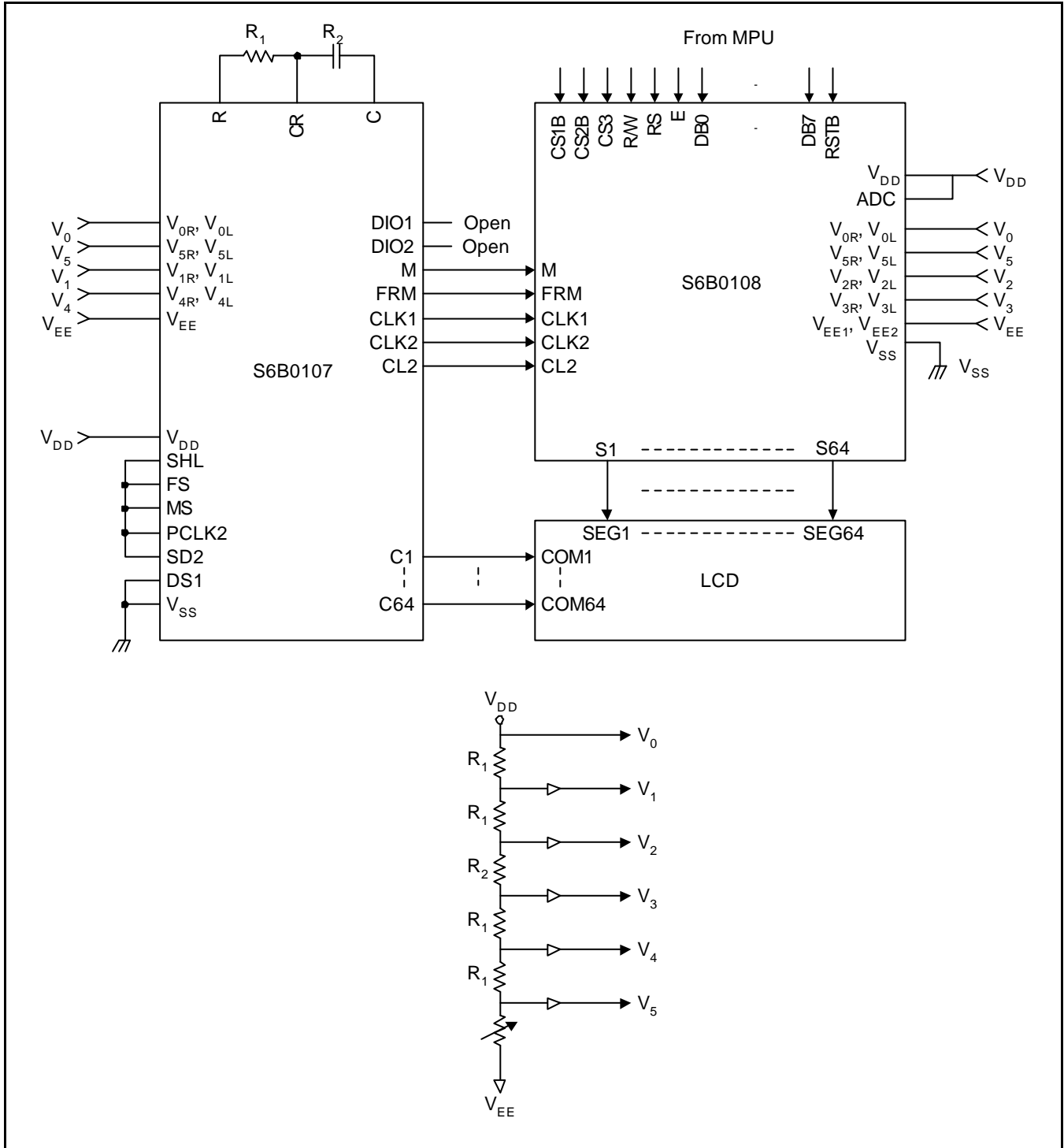

TIMING DIAGRAM (1/64 DUTY)

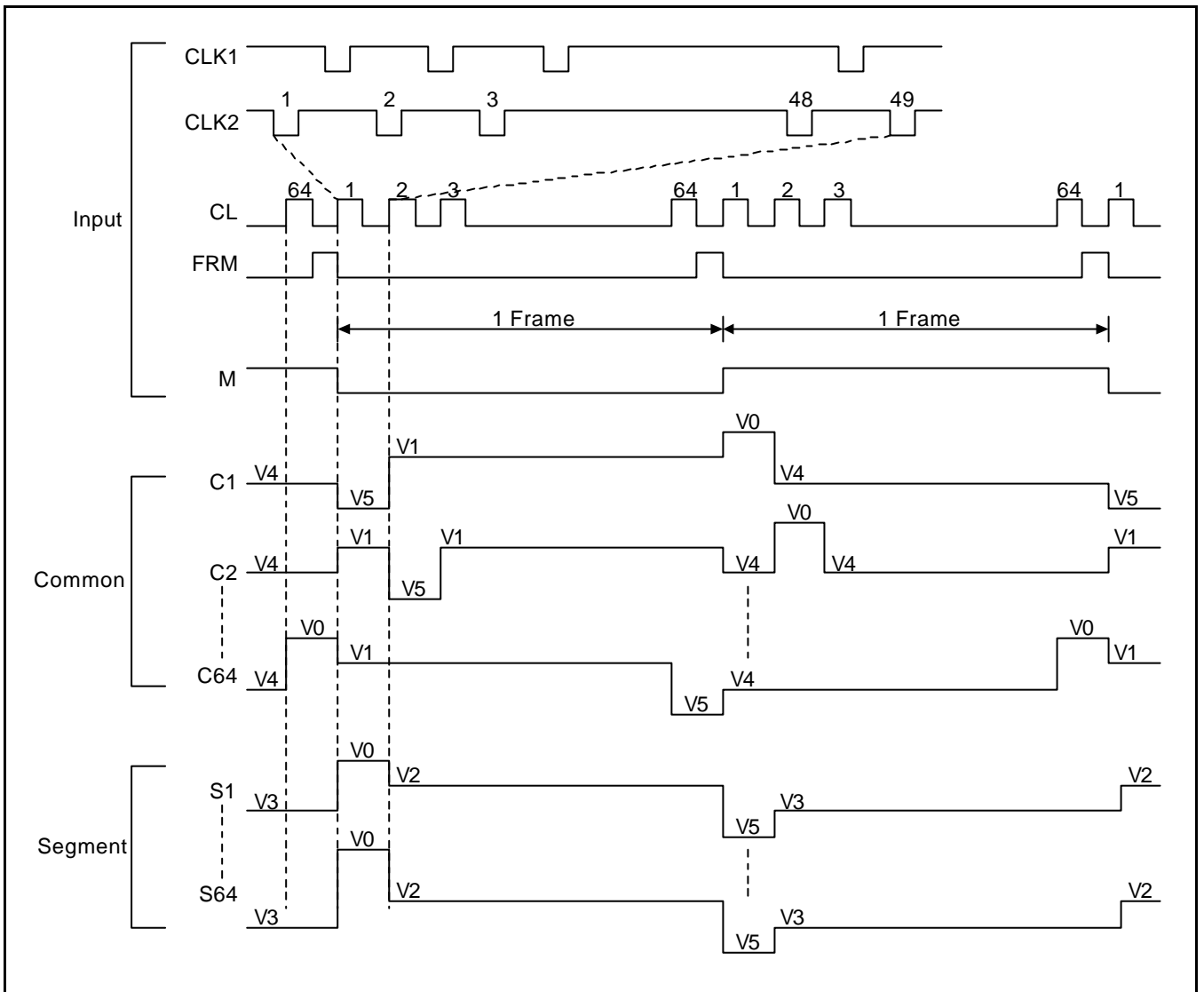

LCD PANEL INTERFACE APPLICATION CIRCUIT

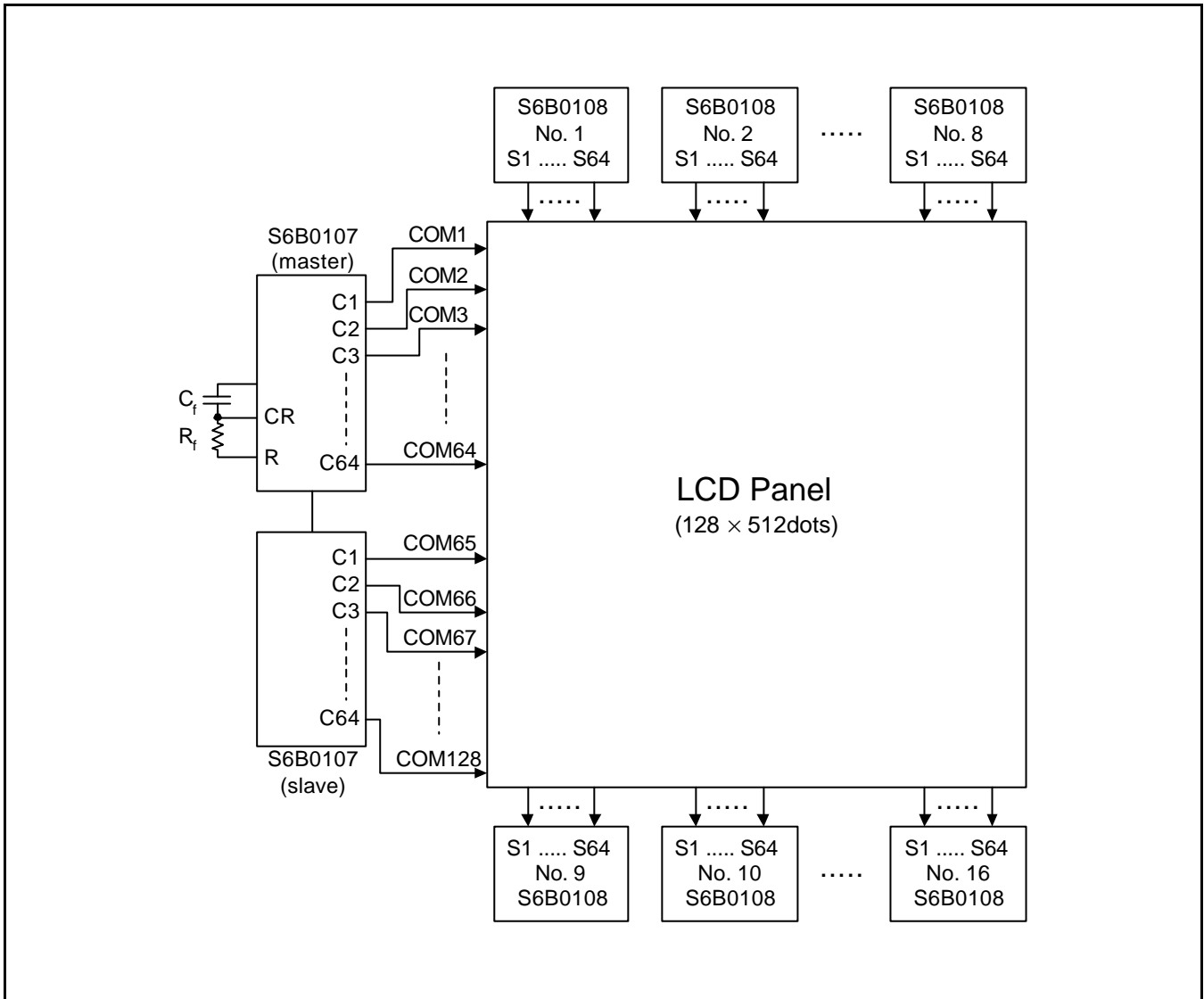



APPENDIX E: CRYSTALFONTZ PN CFAIEL2 EL INVERTER SPECIFICATIONS

To purchase the CrystalFontz DC to AC power EL inverter, (PN CFAIEL2) see [CFAIEL2](#) on our website.

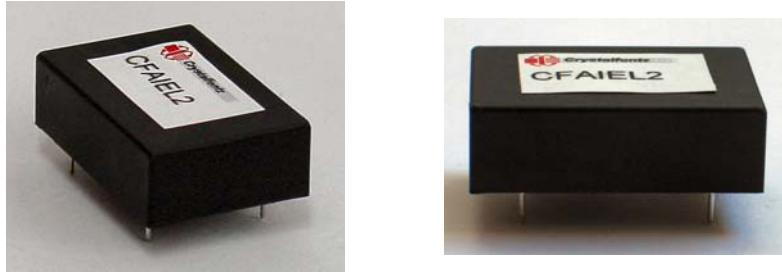

Figure 1. EL Backlight Connection Using Pin 19 and Pin 30

EL INVERTER CHARACTERISTIC	SPECIFICATION
Operating Temperature	-10°C to +70°C
Storage Temperature	-30°C to +80°C
Input Voltage	+5 VDC ($\pm 10\%$)
Output Voltage	+80 VAC ($\pm 15\%$)
Frequency	600 Hz ($\pm 20\%$)
Input Current	60 mADC (typical)
EL Brightness Range	30 to 80 cd/m ²
Test Load	22 nF 66.6 K Ω

NOTE

Do not operate with the output open or shorted. This may ruin the inverter.

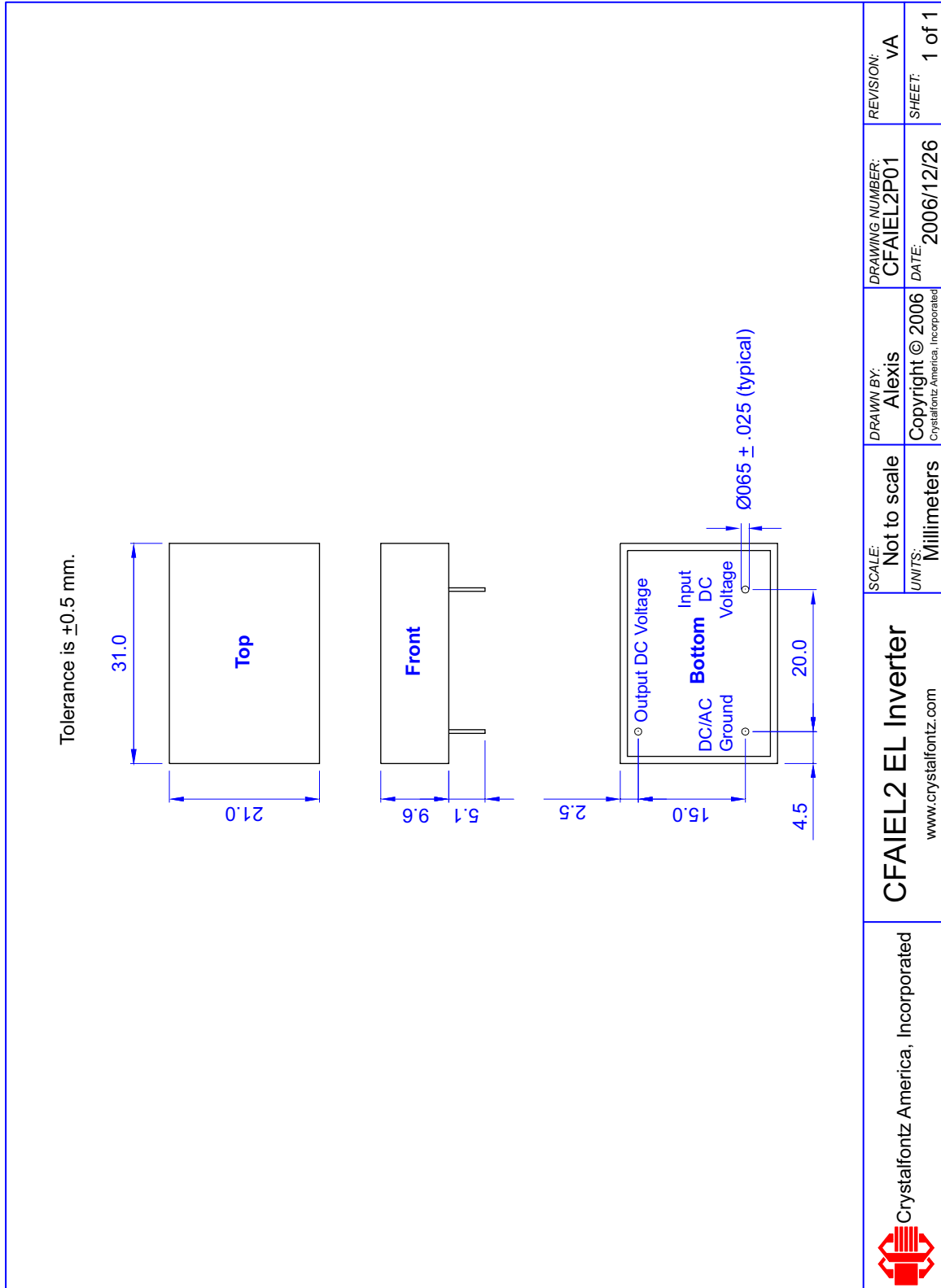

Figure 2. CFAIEL2 EL Inverter Drawing