

IM2000

HIGH PERFORMANCE MICROSTEPPING CONTROLLER ASIC

FEATURES

- Complete Microstepping Control System in the following packages:
 - 68 Pin PLCC (IM2000P)
 - 80 Pin QFP (IM2000F)
 - 64 Pin QFP (IM2000S)
- Up to 10MHz Step Clock Rate
- Internal Sine/Cosine Generator
- PWM Phase Current Control
- Minimal External Components
- Automatic Current Reduction
- 14 Selectable Resolutions — Both in Decimal and Binary
- Number of Microsteps Per Step can be Changed On-The-Fly Without Motor Movement Interruption
- Up to 51,200 Steps/Rev
- Standalone or Buss Modes
- Single 5V Power Supply
- Short Circuit and Over Temperature Protection Inputs
- Fault Output
- On Full Step Output
- Anti-Resonance

DESCRIPTION

The IM2000 is a high performance microstepping controller that incorporates a sine/cosine signal generator, anti-resonance circuitry, PWM current control and much more in one monolithic IC. The IM2000 combines hardware intense functions together with innovative features to provide designers with a powerful yet simple solution for their high volume OEM products.

Never before has any motion product integrated all the digital

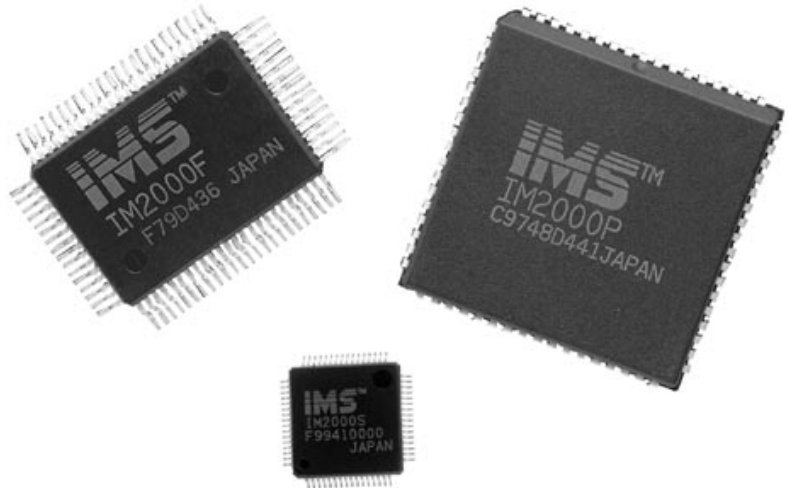

control into one monolithic IC. This high degree of integration can significantly reduce design time as well as driver size.

Beyond the integration of a complete microstepping control system, the IM2000 has unique features that give designers unprecedented control over motor movement. These features include 14 selectable resolutions (in both decimal and binary) that can be changed at any time without motor movement interruption. There is no need to reset the controller. This allows the user to rapidly move long distances, yet precisely position the motor at the end of travel without the need or expense of a complex controller.

Another valuable feature is an "On-Full Step" output which indicates when the motor is at an electrical full step. This output can be used to reduce the overhead needed to track position when making long moves.

The development of proprietary circuits has minimized ripple current, while maintaining a 20 KHz

chopping rate. This prevents additional motor heating that is common with drivers requiring higher chopping rates. Now low inductance stepper motors can be used to improve high speed performance and peak system efficiency.

The IM2000 needs only clock and direction inputs to control the motor and will interface directly to discrete bridges or common monolithic bridge ICs.

Designers can now place drivers directly on their PC boards with all the necessary control in either a 68 pin PLCC package, an 80 pin QFP package, or an ultra small 64 pin QFP package.

Size, price and time-to-market are three crucial aspects in today's competitive markets and the IM2000 offers the ability to reduce all three.

IM2000 PIN DESCRIPTION

80 Pin QFP (F)	68 Pin PLCC (P)	64Pin QFP (S)	NAME	Pin Function
56	4	59	SCLK	Step clock input. A positive going edge on this input will advance the motor one increment (the size of the increment is dependent on the microstep select inputs).
48	65	52	RSEL	ROM select input. When low, this input selects the internal sine/cosine ROM. When high, AD0-AD8 are selected for use with an external lookup table.
54	2	57	RESET	Reset input. When low, this input will reset the IM2000 (PWM, Enable, and Full Bridge outputs will be disabled). When released, the controller will be at its initial state (sine at 0, cosine at peak).
57	5	60	DIR	Direction input. This input is used to change the direction of the motor. Physical direction also depends on the connection of the motor windings.
49	66	53	CSEL	Clock select input. When low, the SCLK input will be directed to the internal sine/cosine generator independent of the level of the EN input. When high, the SCLK input will be directed to the COUT output when the EN input is low and, conversely, to the internal sine/cosine generator when the EN input is high.
58	6	61	EN	Enable input. When low, this input will enable/disable the PWM and full bridge output signals.
59	7	62	FSTEP	On fullstep output signal. This active low output indicates when the IM2000's sine & cosine outputs are positioned on a full step.
61	8	63	FAULT	Fault output signal. This active high output indicates when a fault has occurred. It will stay active until the IM2000 is reset.
62	9	64	WR	Write input. When the IM2000 is configured in the buss mode, this input is used to latch in the microstep select, enable, and direction inputs.
63	10	1	MODE	Mode select input. This input is used to configure the IM2000 in a stand alone or buss mode.
40, 65	58, 12	45, 2	PWMA, PWMB	Phase A and Phase B pulse width modulated output signals. These outputs can be used to control the phase currents in common PWM type power sections.
38, 67	57, 13	44, 3	SIGNA, SIGNB	Sign of A and sign of B output signals. These outputs indicate the sign of the sine and the sign of the cosine.
36, 69	55, 15	43, 4	ENA, ENB	Phase A and Phase B enable output signals. These active high outputs, which work in conjunction with the enable input of PIN 6, can be used to enable/disable the power section of the driver.
37, 68	56, 14	—	ENAN, ENBN	Phase A and Phase B enable NOT output signals. These active low outputs, which work in conjunction with the enable input of PIN 6, can be used to enable/disable the power section of the driver.
30, 31, 34, 35	50, 51, 53, 54	38, 39, 41, 42	HRA, LRA, LLA, HLA	Phase A high side and low side full bridge control signals. These outputs can be used to control discrete P-N or N-N full bridge sections or half and full bridge IC's.
70, 71, 74, 75	16, 17, 19, 20	5, 6, 8, 9	HLB, LLB, LRB, HRB	Phase B high side and low side full bridge control signals. These outputs can be used to control discrete P-N or N-N full bridge power sections or half and full bridge IC's.
78, 80, 1-4, 6, 7	23-30	12-19	COS0-COS7	Cosine waveform output signals for Phase B.
18, 19, 21-25, 27	40-47	28-35	SIN7-SIN0	Sine waveform output signals for Phase A.
42	60	47	IHI	Polarity select input for active high or active low high side full bridge control outputs.
41	59	46	ILOW	Polarity select input for active high or active low low side full bridge control outputs.
28, 77	48, 22	36, 11	VSA, VSB	Phase A and Phase B current sense inputs.
29, 76	49, 21	37, 10	OVCA, OVCB	Phase A and Phase B over current/short circuit protection inputs.
9	32	20	CURRED	Automatic current reduction output signal. This active high output is used to automatically reduce the driver output current 1 second after the last step clock input.
11, 12	34, 35	22, 23	OSCR, OSCRC	Resistor/capacitor inputs for on-board PWM oscillator.
14	36	24	OVV	Over voltage protection input.
16	38	26	OVTMP	Over temperature protection input.
15, 55	3, 37	25, 58	VCC	Supply voltage.
10, 32, 50, 72	18, 33, 52, 67	7, 21, 40, 54	GND	Ground.
43, 44, 46, 47	18, 33, 52, 67	48-51	MSEL0-MSEL3	Microstep resolution select inputs. These inputs are used to select the number of microsteps per full step. The available resolutions (microsteps/step) are: 2, 4, 5, 8, 10, 16, 25, 32, 50, 64, 125, 128, 250, 256.
78, 80, 1-4, 6-8	23-31	12-19	AD0-AD8 (P/F) AD0-AD7 (S)	Address 0 – Address 8 (Address 0 - Address 7 on IM2000S) . These outputs are used in conjunction with external lookup tables for user supplied sine and cosine curves.
17	39	27	COUT	SCLK output. This output is dependent on the CSEL and EN inputs.
51, 52	68, 1	55, 56	CIR0, CIR1	PWM circulation select inputs. These inputs are used to select whether or not the PWM will be in a recirculating or a non-recirculating mode, or an automatic recirculating and non-recirculating mode.
64	11	—	BD	Binary/Decimal select output. This output is used in conjunction with AD0-AD8 when using outside lookup tables. This output is used to choose between binary or decimal encoded tables.

IM2000 ABSOLUTE MAXIMUM RATINGS

Parameter	Symbol	Limits	Units
DC Supply Voltage	V_{DD}	$V_{SS} - 0.3$ to $+7.0$	V
Input Voltage	V_{IN}	$V_{SS} - 0.3$ to $V_{DD} + 0.3$	V
Output Voltage	V_{OUT}	$V_{SS} - 0.3$ to $V_{DD} + 0.3$	V
Storage Temp.	T_{STG}	-65 to +150	°C

RECOMMENDED OPERATING CONDITIONS

Parameter	Symbol	Min.	Typ	Max.	Units
DC Supply Voltage	V_{DD}	4.5	5.0	5.5	V
Input Voltage	V_{IN}	V_{SS}		V_{DD}	V
Operating Temp.	T_{OPR}	-20		85	°C

ELECTRICAL CHARACTERISTICS

$$V_{DD} = +5.0 \pm 10\% \quad T_{OPR} = 25 \text{ } ^\circ\text{C}$$

DC Electrical Characteristics

Symbol	Parameter	Conditions	Min.	Typical	Max.	Units
V_{IL}	Low level input voltage				0.8	V
V_{IH}	High level input voltage		2.0			V
V_{T+}	Schmitt trigger positive going threshold voltage	$V_{DD} = 5.0$		3.0		V
V_{T-}	Schmitt trigger negative going threshold voltage	$V_{DD} = 5.0$	0.6			V
V_H	Schmitt trigger hysteresis voltage	$V_{DD} = 5.0$	0.1			V
I_{IL}	Low level input current	$V_{IN} = V_{SS}$			1.0	mA
I_{IH}	High level input current	$V_{IN} = V_{DD}$			1.0	mA
V_{OL}	Low level output voltage				$V_{SS} + 0.4$	V
V_{OH}	High level output voltage		$V_{DD} - 0.4$			V
I_{OL}	Low level output current				-6.0	mA
I_{OH}	High level output current				3.0	mA
I_{CC}	Supply current					mA

AC Electrical Characteristics

Symbol	Parameter	Min.	Typical	Units
t_{RW}	RESET pulse width	200		nS
t_S	MSEL, SCLK setup time		100	nS
t_{SW}	SCLK pulse width		10	nS
t_{WR}	WR pulse width		20	nS
t_{WH}	Data hold time after WR	0		nS
f_{PWM}	PWM chopping frequency		20	KHz
f_{CLK}	SCLK input frequency		10	MHz

PACKAGING INFORMATION

Dimensions in Inches (mm)

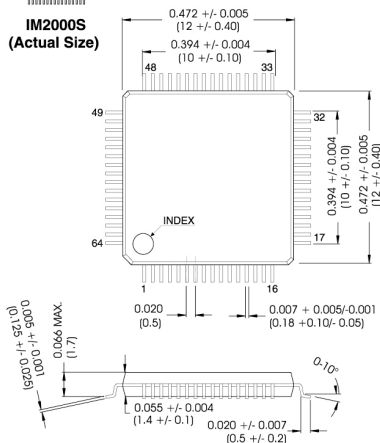
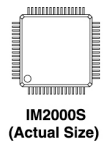

IM2000S / 64 PIN QFP
(Enlarged)

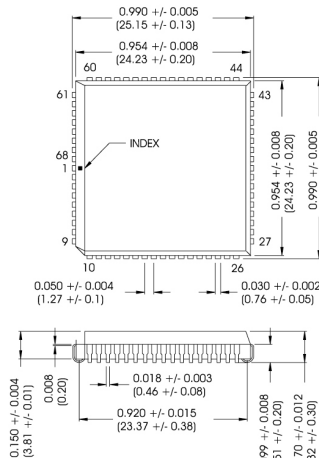

IM2000P / 68 PIN PLCC
(Actual Size)

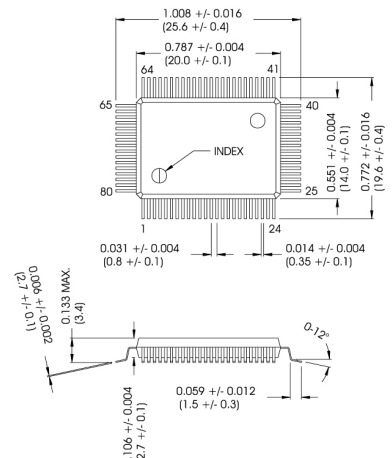

IM2000F / 80 PIN QFP
(Actual Size)

BLOCK DIAGRAM

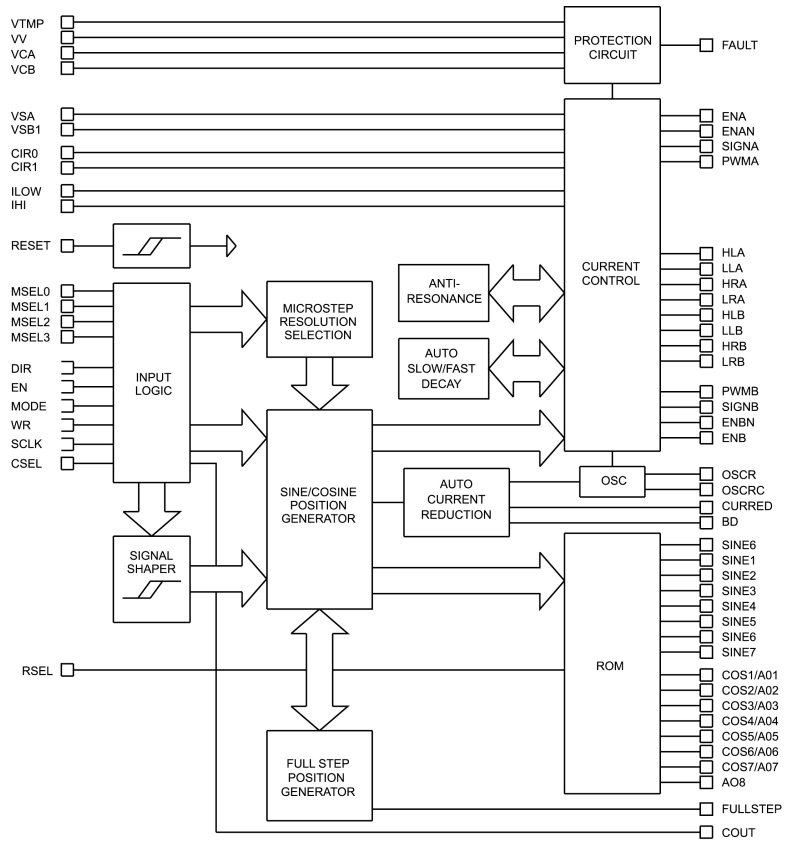

TYPICAL APPLICATION

48V, 3 Amps (RMS)/Phase Microstepping Driver

Output Current (AMPS) = $.002 \times R1$ (OHMS)

NOTE: Diodes may be needed on phase outputs depending on input voltage and phase currents used.

